



AUTODESK®
ADVANCE STEEL



Custom Connections

Table of Contents

AUTODESK ADVANCE STEEL CUSTOM CONNECTIONS	5
INTRODUCTION.....	6
STANDARD ELEMENTS AS CUSTOM CONNECTIONS	7
AUTOMATIC JOINTS AS CUSTOM CONNECTIONS	13
AUTOMATIC JOINTS AND THEIR USE	13
AUTOMATIC JOINTS AS CUSTOM CONNECTIONS	15
INTELLIGENT BRICKS AS CUSTOM CONNECTIONS	20
INTELLIGENT BRICKS AND THEIR USE	20
<i>Plate along beam flange</i>	<i>21</i>
<i>Plate on beam flange</i>	<i>24</i>
<i>Plate parallel beam flange</i>	<i>26</i>
<i>Plate along beam web</i>	<i>28</i>
<i>Plate on beam web</i>	<i>30</i>
<i>Plate parallel beam web.....</i>	<i>32</i>
<i>Bolts on beam</i>	<i>34</i>
<i>Bolts on gauge line</i>	<i>37</i>
<i>Studs on beam</i>	<i>39</i>
<i>Bolts/Anchors/Holes on plate.....</i>	<i>41</i>
<i>Studs on plate</i>	<i>43</i>
<i>Galvanizing holes.....</i>	<i>45</i>
<i>Plate on plate</i>	<i>47</i>
<i>Plate perpendicular to plate</i>	<i>49</i>
<i>Plate at plate edge</i>	<i>51</i>
<i>Spacer plates</i>	<i>53</i>
<i>Shim plates at bolts.....</i>	<i>56</i>
<i>Outside stiffener</i>	<i>58</i>
<i>Beam on object reference to object.....</i>	<i>60</i>
<i>Plate on object reference to object</i>	<i>63</i>
<i>Hole in beam reference to beam</i>	<i>65</i>
INTELLIGENT BRICKS AS CUSTOM CONNECTIONS	67

**AUTODESK ADVANCE STEEL CUSTOM
CONNECTIONS**

Introduction

Starting with version 2013 of Autodesk Advance Steel, you have the possibility to define, save and reuse Custom Connections. You can find all required functions in the tool palette, "**Custom Connections**" category.

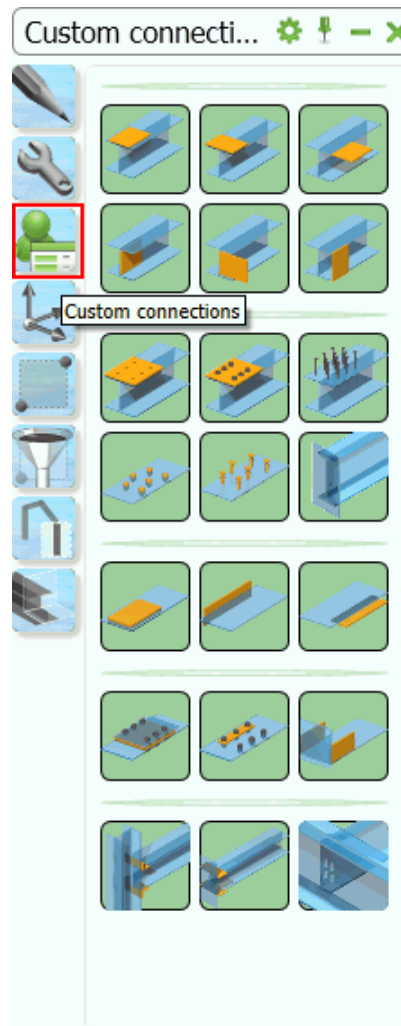

Custom Connections can be defined as follows:

- ✓ From all standard elements like beams, plates, special parts, folded plates, bolts, welds, features, weld preparations, etc.
- ✓ From automatic joints
- ✓ From intelligent bricks

You can also combine parts from all the groups mentioned above.

The purpose of this tutorial is to show you the different possibilities of defining and reusing Custom Connections.

Standard Elements as Custom Connections

Starting with version 2013 of Autodesk Advance Steel, you have the possibility to convert standard element like beams, plates, special parts, folded plates, bolts, welds, features, weld preparations, etc. to intelligent Custom Connections, to save them and to reuse them in other projects. Therefore, one requirement is to save the DWG-file in which you have defined the Custom Connection at the path **C:\ProgramData\Autodesk\AdvanceSteel\2015\Shared\ConnectionTemplates**, so that the drawing can be accessed later by Advance Steel, when you want to reuse the Custom Connection.

One of these drawings can contain several Custom Connections and the path mentioned above can contain several drawings.

If you create Custom Connections directly in your model, these Custom Connections can be reused only in this project. This can be useful for special situations, too.

Now, open a new drawing first by using the template AStemplate.dwt.

Note: *You can also create all elements for the Custom Connection in your current model and then insert all the parts needed for the Custom Connection into a separate DWG-file by using the command "block". You must save the new file at the path mentioned above.*

Create all parts which are important for the Custom Connection, including the components which will be connected by the joint, in the new drawing.

For this tutorial, we want to create the following connection:

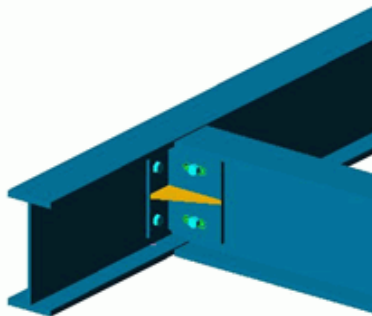

Make sure that all standard elements which are important for the Custom Connection are visible and can be selected, including all the green frames for features, and all the welds.

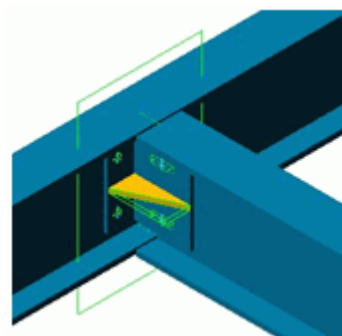

Save the DWG-file at

C:\ProgramData\Autodesk\Advance Steel\2015\Shared\ConnectionTemplates\AngleConnection.dwg.

Now, create the Custom Connection by using the command "Create connection template" from the tool palette, "Custom Connection" category.

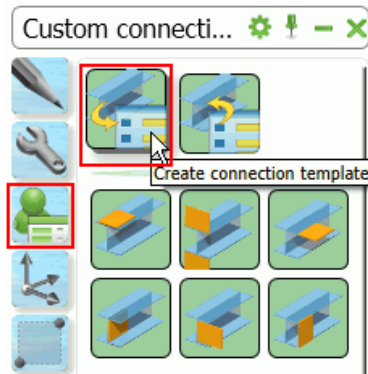

The window "Choose the definition method" appears.

In our example, we want to insert the new Custom Connection depending on a main and a second beam, so we choose "2 beams" from the menu.

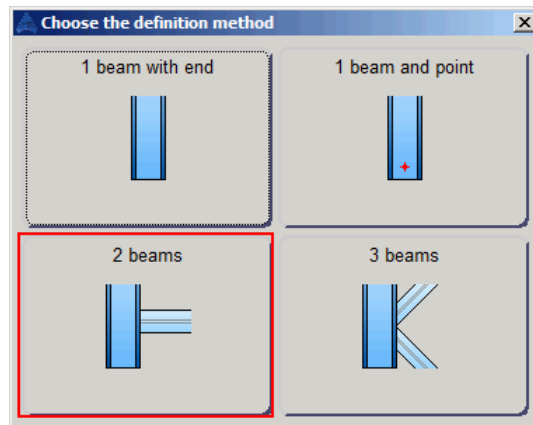

The following prompt appears:

Select input beam:

Select the main beam first and confirm your selection by right click; select the second beam and confirm your selection by right click. Now both beams are defined.

The window "User template" appears.

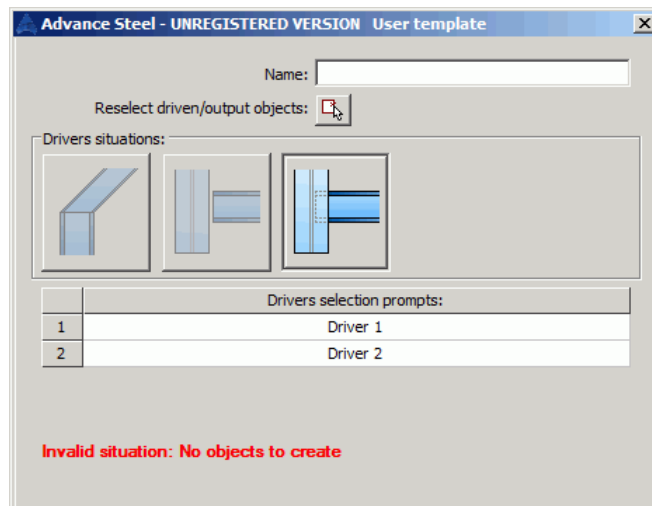

Enter the name of the Custom Connection in the "**Name**" field, e.g. "Angle Connection".

You can select the parts of the joint by pressing the  button behind "**Reselect driven/output objects**". Press the button and select all parts e.g. by window, make sure that all features and connecting elements (bolts, welds, etc.) are selected too.

In the fields of the "**Drivers selection prompts**:" table you can enter the terms which will appear in command line when you reuse the Custom Connection to select the members of the joint. If you click in one of the lines of the table, the corresponding element in the model will be marked red and you can modify the text in this line.

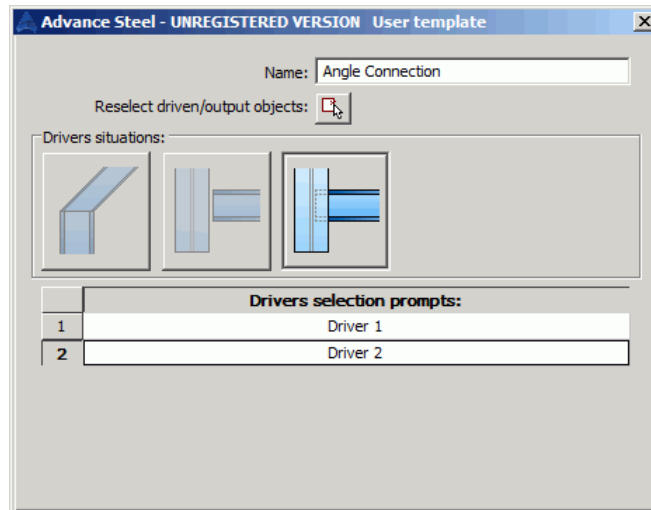

After you have done all required settings in this window, close it by pressing X in the upper right corner. The Custom Connection was created successfully. In the model you can see this on the blue box, which includes all elements, which belong to the Custom Connection.

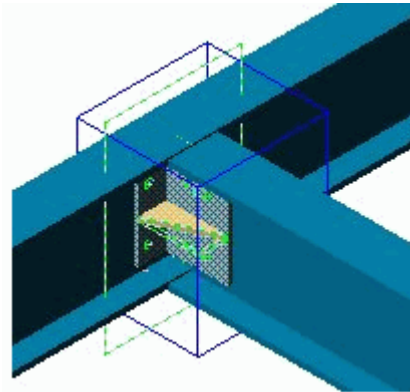

Go back to your model to reuse the new Custom Connection named "Angle Connection" there.

Initial situation:

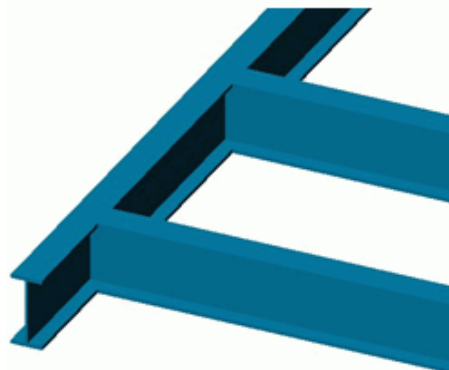

Click "Insert connection template" from the tool palette, "Custom Connection" category.

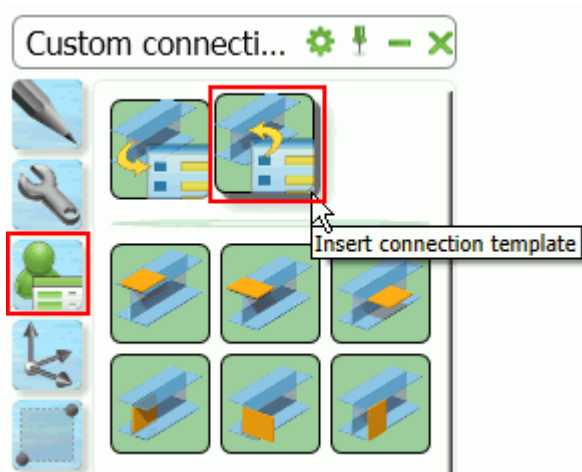

The "Connection template explorer" appears. Here you can see on the left side the "Angle.dwg" category (name of the drawing containing the Custom Connection) and the Custom Connection itself. At the right side you can see a preview of the Custom Connection. Above the preview you can find all commands for zoom, pan and orbit.

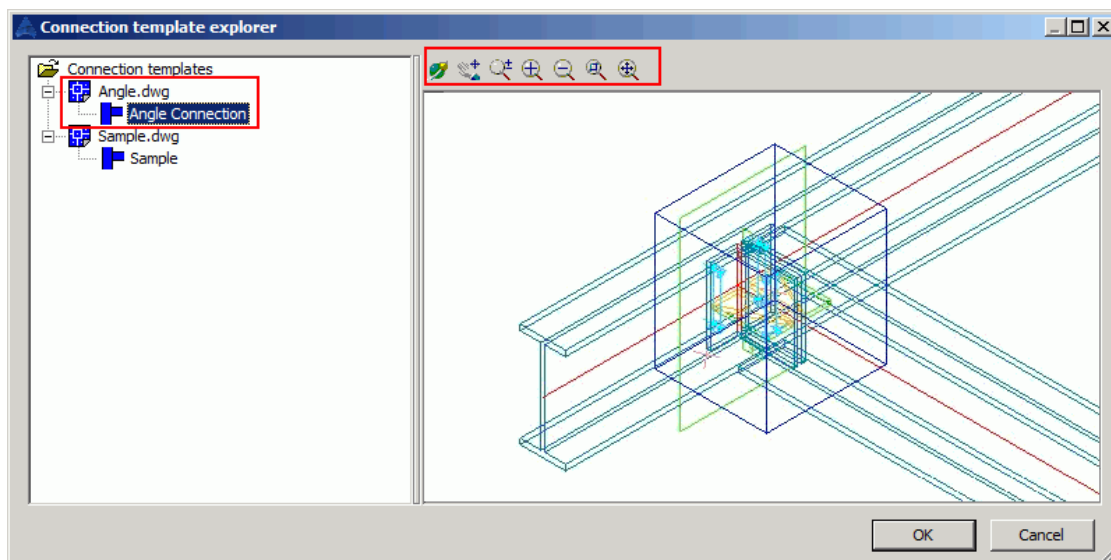

Select the Custom Connection and press "OK".

In the command line, the terms which you have specified during the definition of the Custom Connection appear.

Select the corresponding elements in the model.

The Custom Connection is inserted. This connection can be identified by a blue box in the model as Custom Connection.

The "User template" window with the properties of the Custom Connection appears.

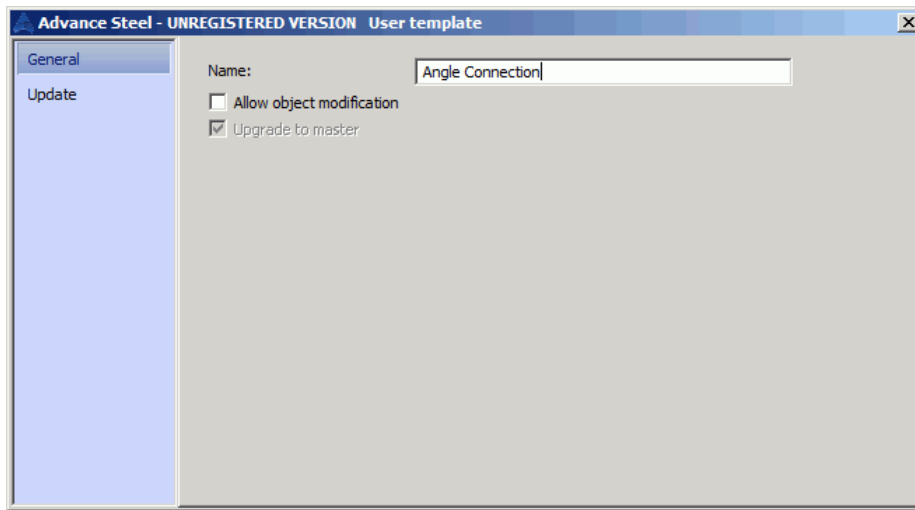

All settings are greyed out here, because the Custom Connection is exactly the same as the template connection you have defined. The settings within the properties dialog boxes of the connection members are greyed out, too. This situation we know from the automatic joints.

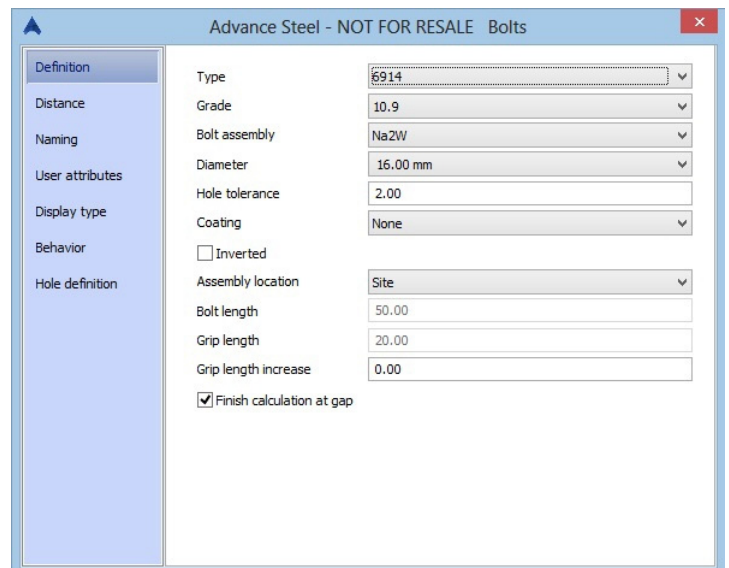
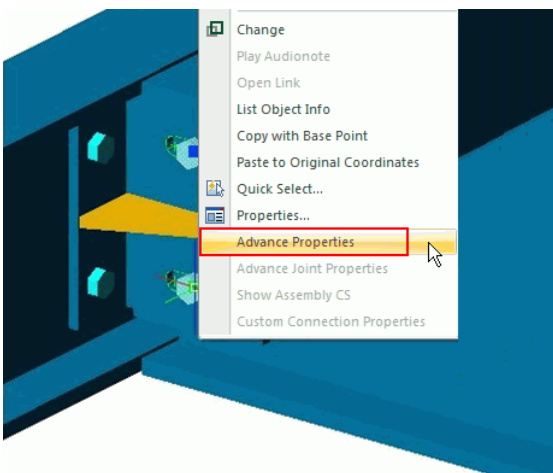

If you have to modify properties of the Custom Connection later, you can do this without deleting the blue box and destroying the intelligence of the Custom Connection by selecting the blue box, making a right click and choosing "Custom Connection Properties" from the context menu.

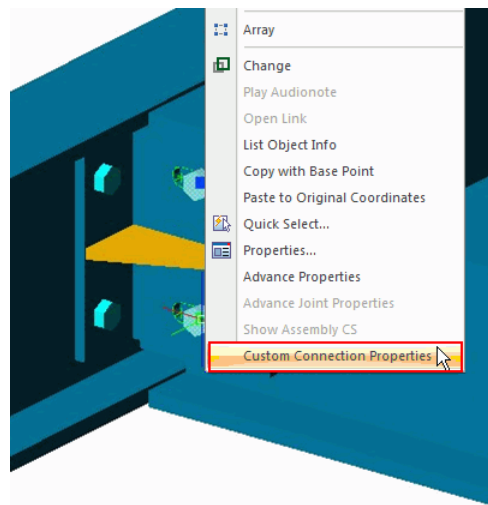

The window "User template" appears again and you can activate the option "Allow object modification". Now you can modify the properties of all elements of the Custom Connection without losing the connections intelligence.

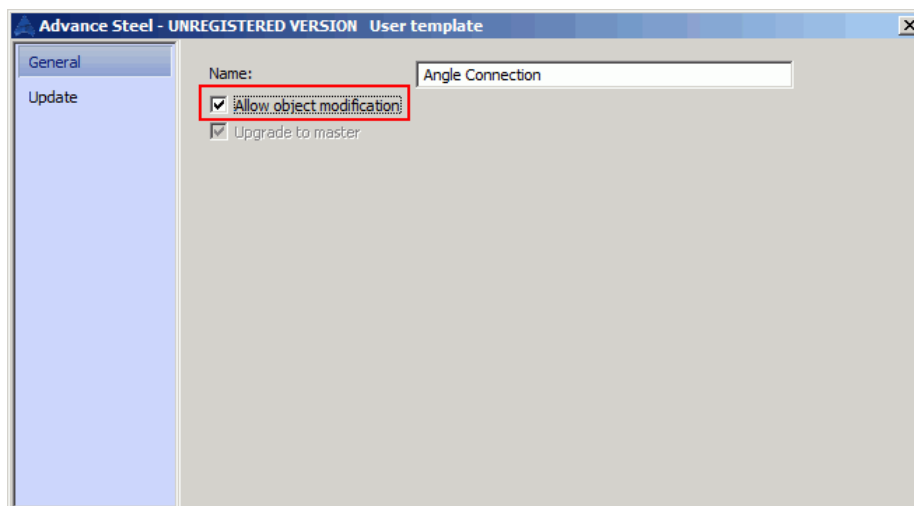

Now all "Advance Properties" e.g. of the bolts can be modified:

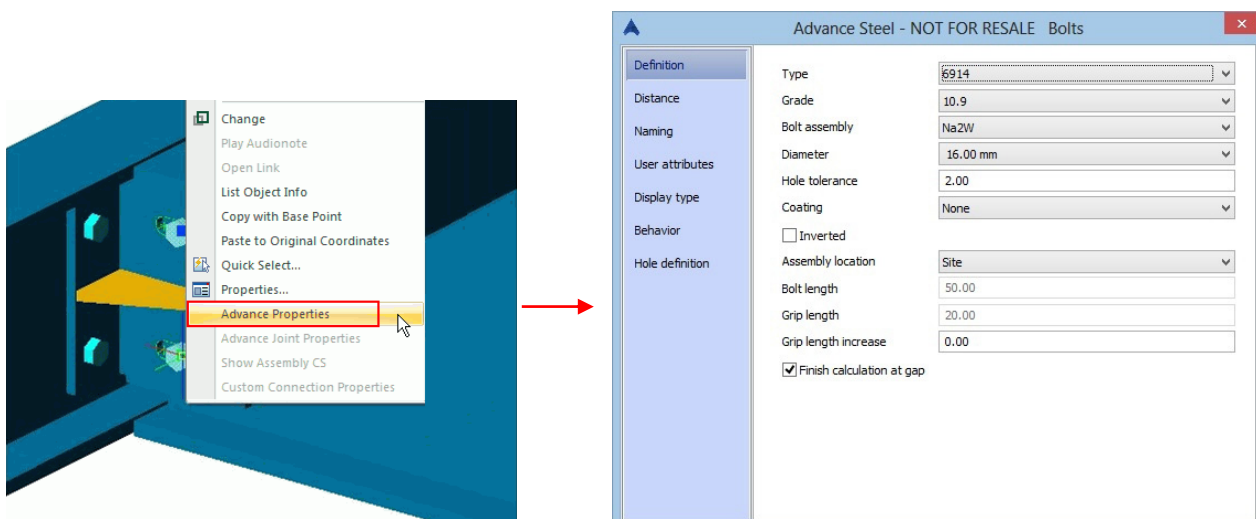

Automatic Joints as Custom Connections

Automatic Joints and their use

Automatic Joints are intelligent connections, which you can insert in your model by using **Connection vault** of Advance Steel. You can find the **Connection vault** in the ribbon "**Extended Modeling**", category "**Joints**":



You can use all joints from the **Connection vault** at any time in your Autodesk Advance Steel model, at any situation, which fits to the properties of the joint and how often you need them.

Depending on the joint, the properties dialog box contains many settings to adapt the connection to the situation in the model.

If you need the same joint many times within one model with the same properties, you can use the command "Create by template", which you can find in ribbon "Extended Modeling", category "Joint Utilities" to do this.

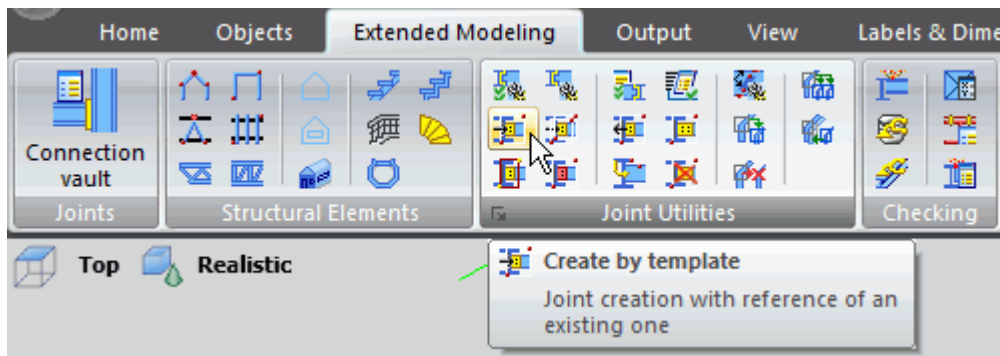

If you need some automatic joints with special settings in different models, then you can insert this joint in a model and make all settings you need. After that you can go the tab "Library" in the properties dialog box of the joint and save the settings by pressing the button "Import values". After that you can modify the values by pressing the button "Edit" if needed.

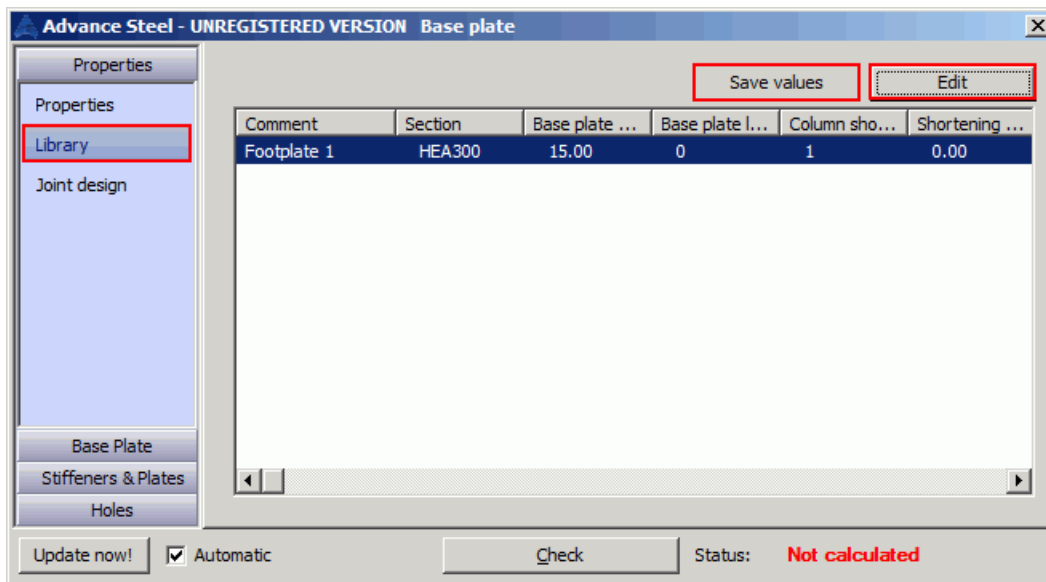

If you reuse this joint later in another model for the same beams, then Autodesk Advance Steel recognizes that you have saved values for this joint and this combination of beams and uses the stored values. If you change the values in the properties dialog box, this has no effect to the values in the table or to joints in other models, which were created by the entries of the table. All these joints are independent.

Automatic Joints as Custom Connections

Often you have to combine several automatic joints to get the required connection.

Since Version 2013 of Autodesk Advance Steel we have the possibility to combine several automatic joints, save the result and reuse it in other models as Custom Connection.

The procedure for this is illustrated with the following example:

A railing post must be connected with the main beam by using the "End plate with bolts" joint. In addition, we want to have a stiffener below the post using the joint "Stiffener". Because we want to use this combination of automatic joints in other models later again, we will combine both automatic joints in one Custom Connection.

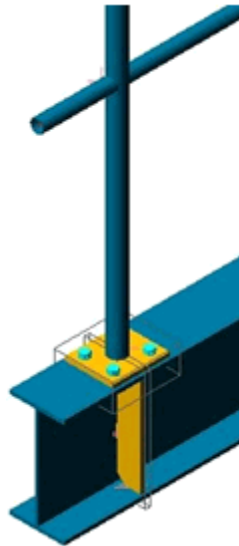

Open a new DWG-file using the template **ASTemplate.dwt**.

Save this file e.g. with the name "railingjoints.dwg" in the path

C:\ProgramData\Autodesk\Advance Steel\2015\Shared\ConnectionTemplates.

Now, insert first the involved elements (main beam and railing post) and both joints. Then set the required properties. Make sure that the grey boxes of the automatic joints are visible and can be selected.

Click "**Create template connection**" from tool palette, category "**Custom Connection**".

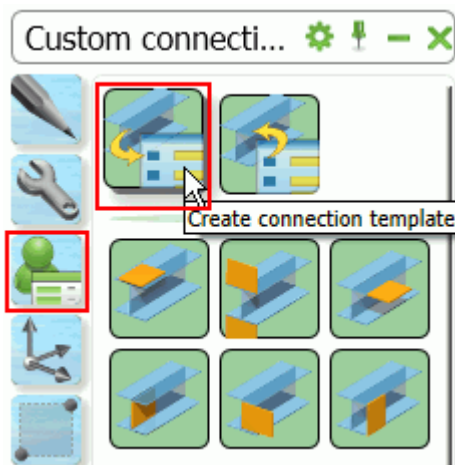

The window "**Choose the definition method**" appears.

In our example we want to insert the new Custom Connection depending on a main and a second beam, so we choose "**2 beams**" in the menu.

Select input beam:

Now select the main beam and confirm your selection by right. Select the second beam then and confirm your selection by right click. Both beams are defined now.

The window "User template" appears.

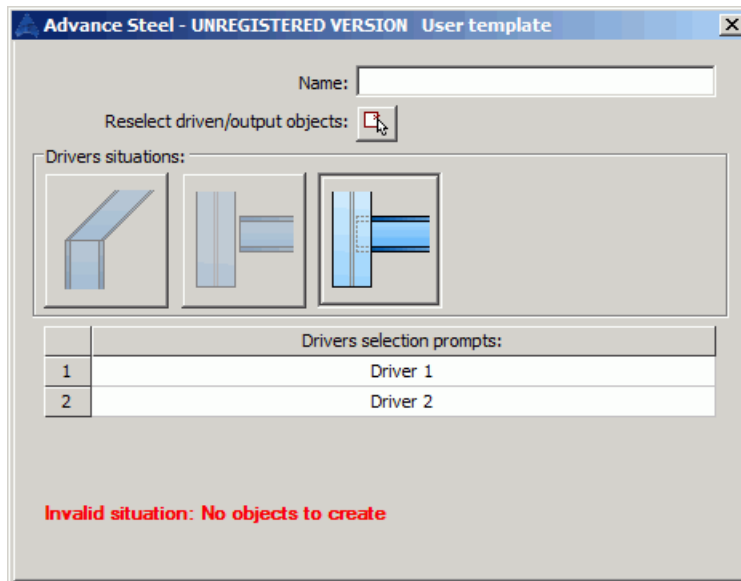

Enter the name of the Custom Connection in field "Name", e.g. "Railing with stiffener".

You can select the members of the joint by pressing the button  behind "Reselect driven/output objects". Press the button and select the members of the joint (e.g. by window) make sure that all features and connecting elements (bolts, welds, joint boxes, etc) are selected, too.

In the fields of the table "Drivers selection prompts:" you can enter the terms, which will appear in command line when you reuse the Custom Connection to select the members of the joint. If you click in one of the lines of the table, the corresponding element in the model will be marked red and you can modify the text in this line.

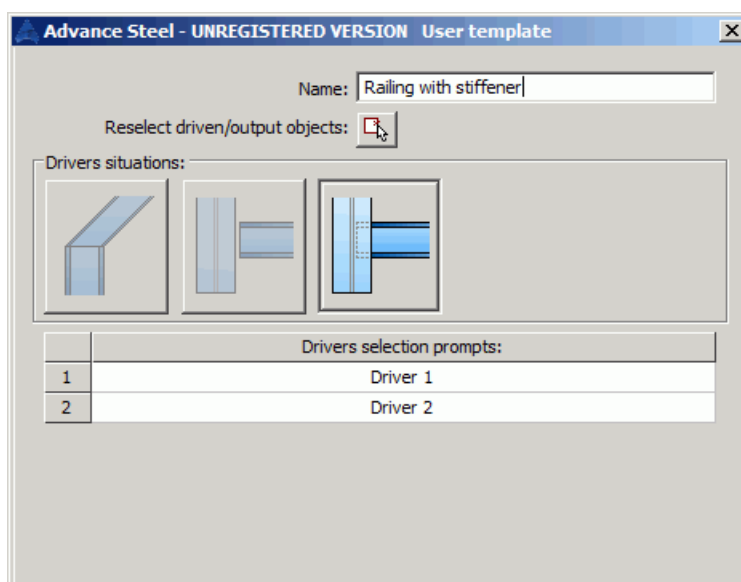

After you have done all required settings in this window, close it by pressing the red X in the upper right corner. The Custom Connection was created. In the model you can see this on the blue box, which includes all elements, which belong to the Custom Connection.

Go back to your model to reuse the new Custom Connection there.

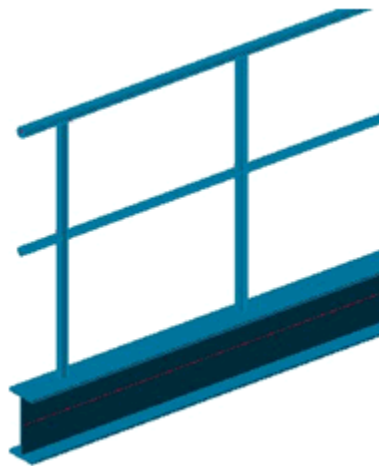

Click "Insert connection template" from the tool palette, category "Custom Connection".

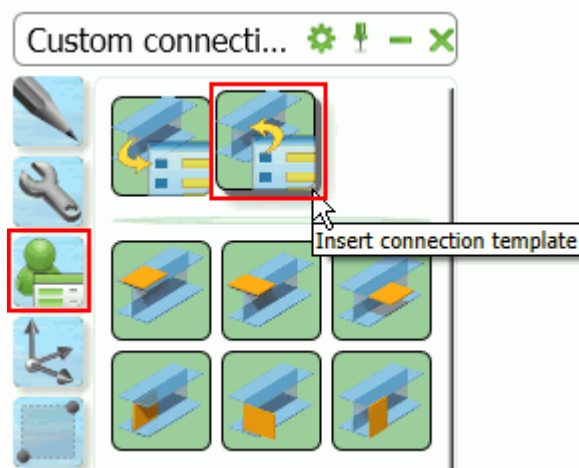

The "Connection template explorer" appears. Here you can see at the left side the category "Railing connection.dwg" (name of the drawing containing the Custom Connection) and the Custom Connection itself. At the right side you can see a preview of the Custom Connection. Above the preview you can find all commands for zoom, pan and orbit.

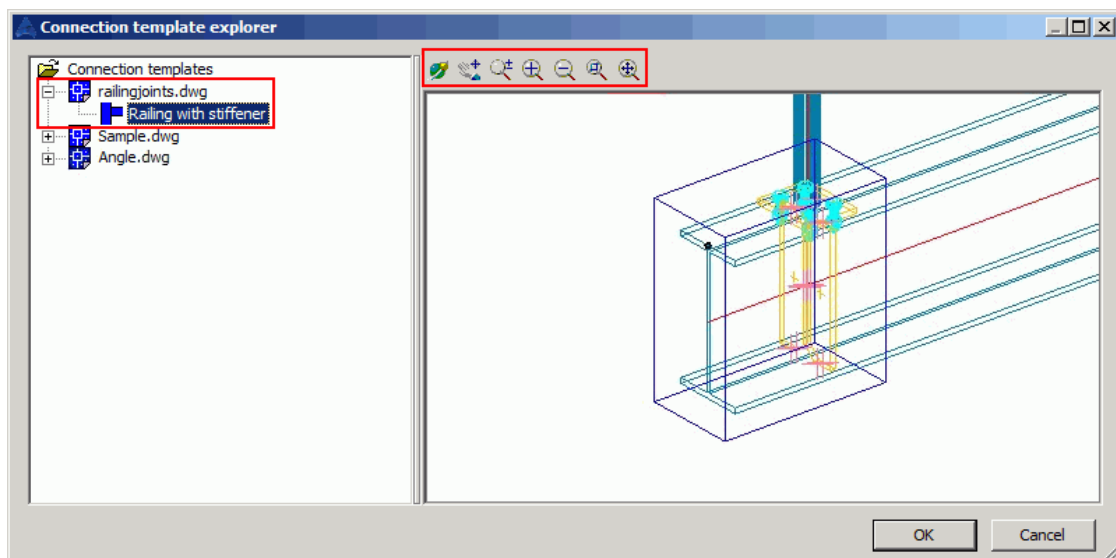

Select the Custom Connection and press "OK".

In the command line the terms, which you have specified during the definition of the Custom Connection, appear. Select the corresponding elements in the model.

The Custom Connection is inserted. This connection can be identified by a blue box in the model as Custom Connection.

The window "User template" with the properties of the Custom Connection appears.

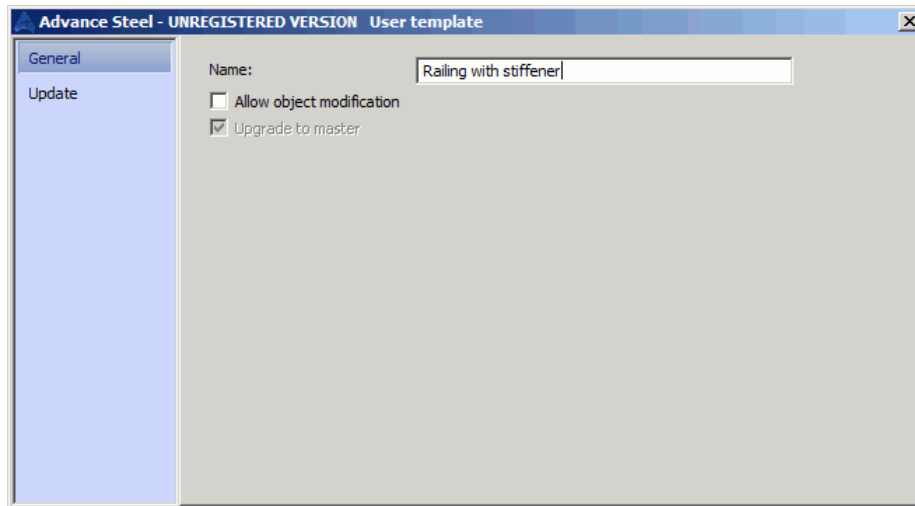

All settings are greyed out here, because the Custom Connection is exactly the same as the template connection you have defined.

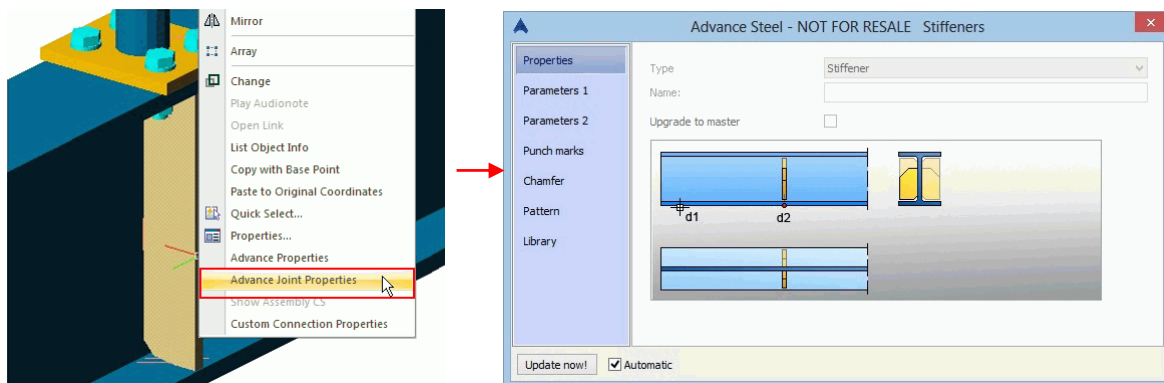

If you have to modify properties of the Custom Connection later, you can do this without deleting the blue box and destroying the intelligence of the Custom Connection by selecting the blue box, making a right click and choosing "Custom Connection Properties" from the context menu.

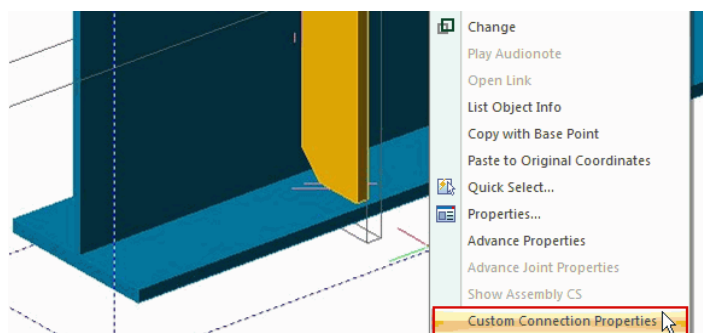

The window "User template" appears again and you can activate the option "Allow object modification". Now, you can modify the properties of all elements of the Custom Connection without losing the connections intelligence.

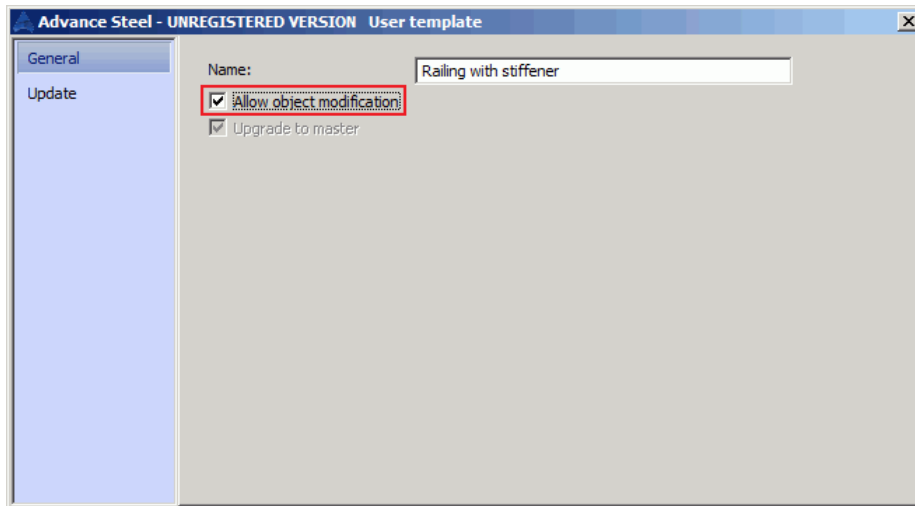

Now all Autodesk Advance Steel Properties of the automatic joints can be modified again, without destroying the intelligence of the Custom Connection.

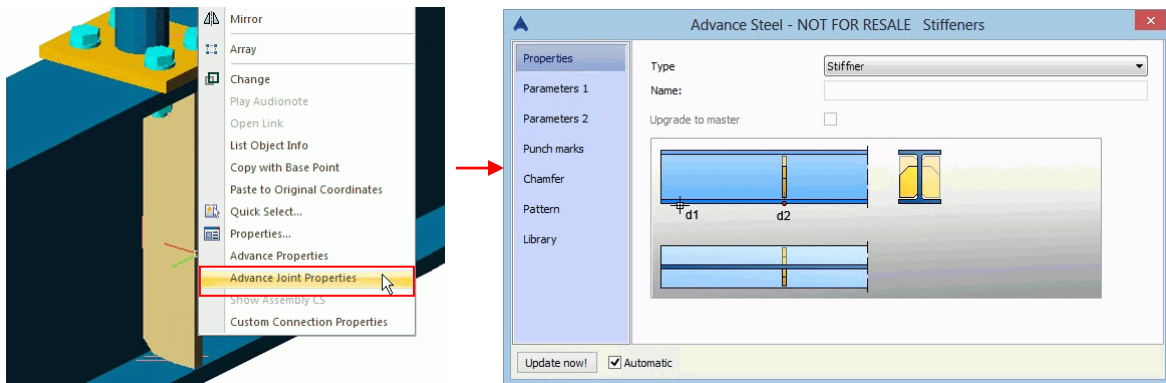

Intelligent Bricks as Custom Connections

Intelligent Bricks and their use

A third method to define Custom Connections is represented by the intelligent bricks in Autodesk Advance Steel. With these intelligent bricks you can insert basic elements very quickly and easily. In addition, these basic elements can get an intelligent relationship to the beam or the plate to which they belong. This means, if the reference element will be modified, the part inserted by an intelligent brick will be modified in the same way too. In the model such a relation is marked by a grey box, as we know from the automatic joints already.

The intelligent bricks are sorted in five groups in the menu:

- plate at beam
- connecting elements (at beam or plate)
- plate at plate
- shim / stiffener
- with reference object

You can find the intelligent bricks in tool palette, in category "**Custom Connection**".

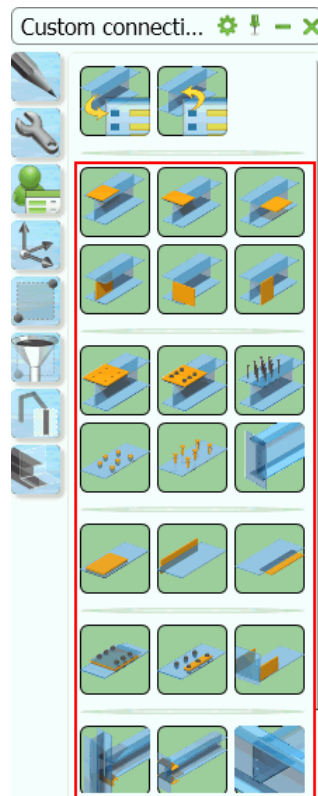

All intelligent bricks can be used together with virtually any element type in Autodesk Advance Steel, with the exception of e.g. curved beams or folded plates. However, not all options in bricks properties windows are useful for all element types in Advance Steel.

Below you will find an overview of the intelligent bricks and their properties.

Plate along beam flange

This intelligent brick adds up to two plates along the flange of an existing beam in the direction of the system line of the beam. The orientation of the beam is irrelevant. The beam can also be part of a structural element and can already have features or connecting elements.

Due to the internal coordinate system, generated during the creation of each beam in Advance Steel, all beams have flanges, even pipes. Hence, this brick can be used for pipes, too.

The plate can be added parallel or perpendicular to the flange. If it is perpendicular, the plate will always be set above the centre of gravity of the beam (default system line location).

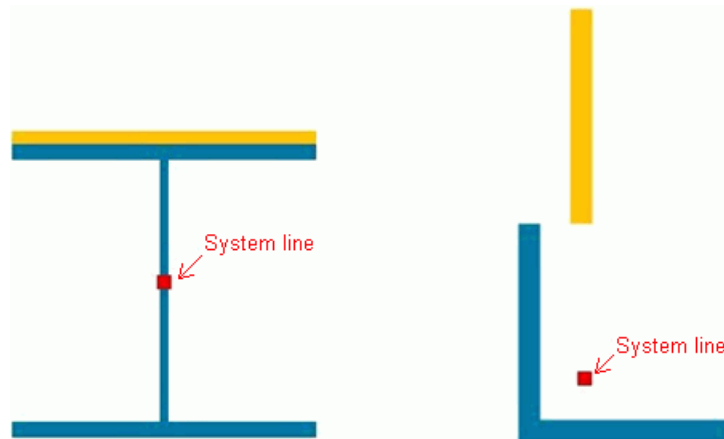

The size of the plate can be defined by length and width or by projections and offsets, so the size of the plate can have an intelligent relation to the size of the flange or the end of the beam.

Example:

Click "**Plate along beam flange**" from tool palette, category "**Custom Connection**".



Select beam

Select the beam at one end.

The command stops automatically and the plate is added at this end of the beam, which is closest to the selected point.

The plate is surrounded by a grey box, so that you can see in the model that the plate is not just a common plate.

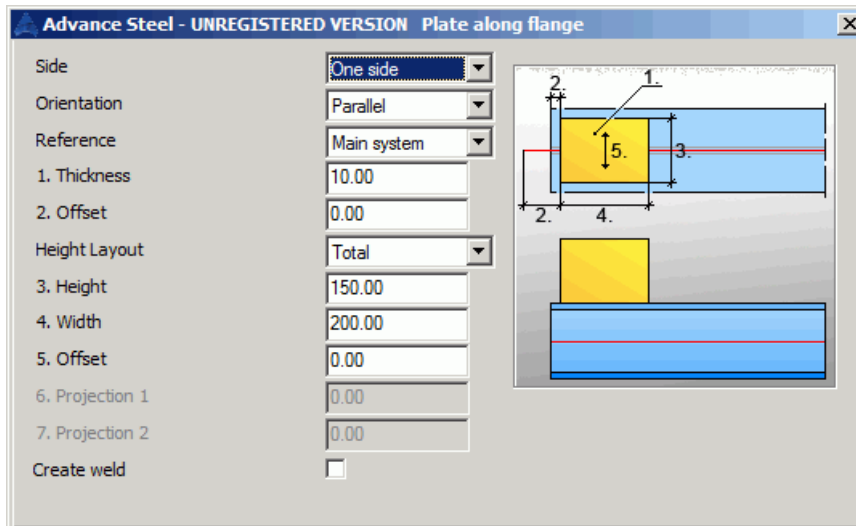

- Side** You can define if one plate is added to one of the flanges or to the other flange, or if two plates are added, each one at each flange.
- Orientation** You can set the plate(s) parallel or perpendicular to the flange.
- Reference** This option is set to "**Main system**" by default. This means, that the plate will always be added to the end of the system line. If the beam already has a shortening, the plate is not entirely on the beam. With "**Main physical**" the plate will be moved to the physical end of the beam. So if you have to modify the value of the feature later, the plate will move to the new end of the beam automatically.
- 1. Thickness** Thickness of the plate.
- 2. Offset** Distance of the plate from the physical end of the beam. Here you can define an intelligent relation to the end of the beam.
- Height Layout** Here you can set how the size of the plate will be defined. With the option "**Total**" the height of the plate will be defined as total height with "**3. Height**". If you choose the setting "**Projection**" then the values "**6. Projection 1**" and "**7. Projection 2**" will be used.
- If you modify the size of the beam later, the size of the plate will be adapted to the size of the new flanges automatically.
- 3. Height** Height of the plate
- 4. Width** Width of the plate
- 5. Offset** If you have set "**Total**" for the option "**Height Layout**" then here you can define the offset of the plate across the beam,.
- 6. Projection 1** Projection at one flange edge. Negative values are permitted.
- 7. Projection 2** Projection at the other flange edge. Negative values are permitted.
- Create weld** The plate will be welded to the beam by fillet weld, thickness 4 mm. You can modify the properties of the weld in the properties dialog box of the weld.

If you want to open this properties dialog box later again, please select the plate or the grey box, right click and choose from the context menu "**Advance Joint Properties**".

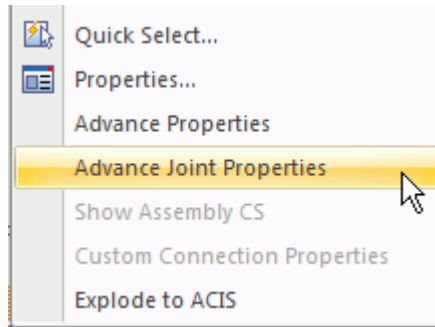

The Autodesk Advance Steel properties of the plate are partially greyed out because they are controlled by the properties of the intelligent brick.

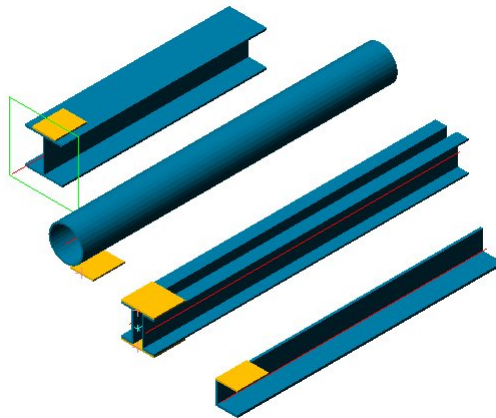
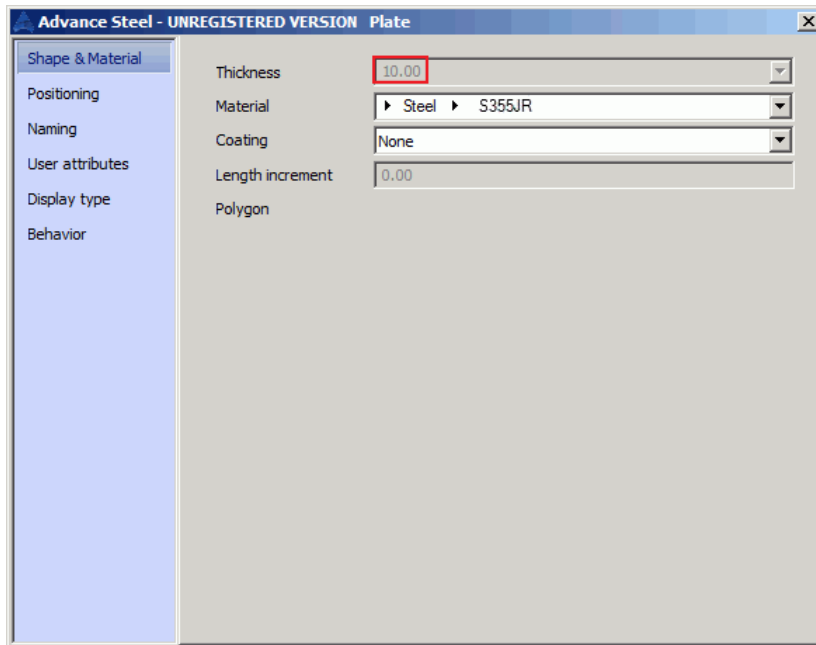
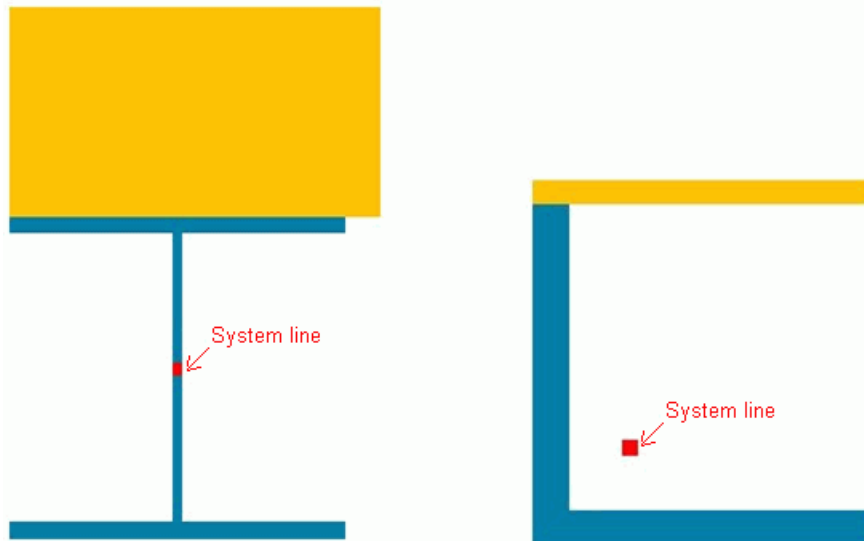

Plate on beam flange

This intelligent brick adds up to two plates at the flange / flanges of an existing beam transverse to the direction of the system line. The orientation of the beam is irrelevant. The beam can also be part of a structural element and can already have features and connecting elements.

Due to the internal coordinate system, generated during the creation of each beam in Advance Steel, all beams have flanges, even pipes. Hence, this brick can be used for pipes, too.

The plate can be added parallel or perpendicular to the flange.



The size of the plate can be defined by length and width or by projections, so the size of the plate can have an intelligent relation to the size of the flange.

Example:

Click "**Plate on beam flange**" from tool palette, category "**Custom Connection**".

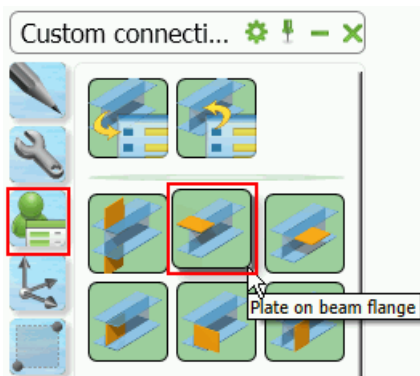

Select beam

Select the beam at one end.

The command stopped automatically and the plate is added at this end of the beam, which is closest to the selected point.

The plate is surrounded by a grey box, so that you can see in the model that the plate is not just a common plate.

If you want to open this properties dialog box later again, please select the plate or the grey box, right click and choose from the context menu "**Advance Joint Properties**".

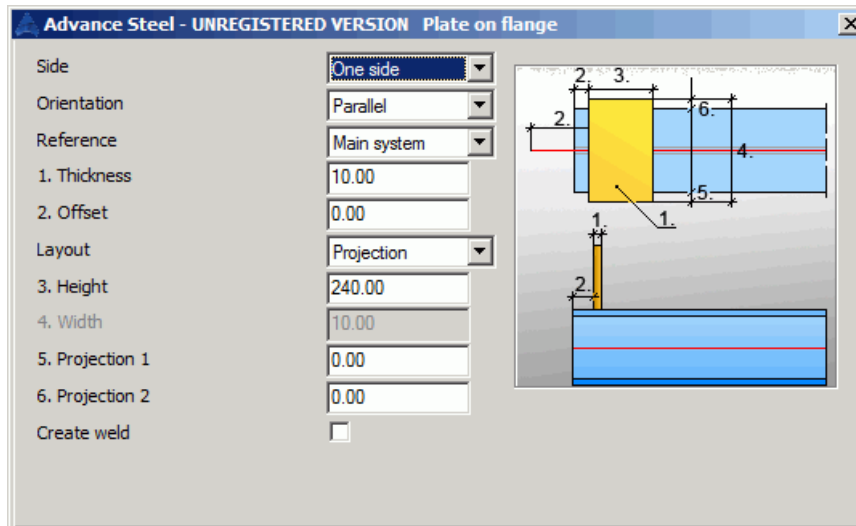
**Side**

You can define if one plate is added to one of the flanges or to the other flange, or if two plates are added, one at each flange.

Orientation

You can set the plate / the plates parallel or perpendicular to the flange.

Reference

This option is set to **"Main system"** by default. This means that the plate will always be added to the end of the system line. If the beam already has a shortening, the plate is not entirely on the beam. With **"Main physical"** the plate will be moved to the physical end of the beam. So, if you have to modify the value of the feature later, the plate will move to the new end of the beam automatically.

1. Thickness

Thickness of the plate.

2. Offset

Distance of the plate from the physical end of the beam. Here you can define an intelligent relation to the end of the beam.

Layout

Here you can distinguish if the width of the plate will be defined as total width with **"4. Width"** or by **"Projection"** with values **"5. Projection 1"** and **"6. Projection 2"**. If you modify the size of the beam later, the size of the plate will be adapted to the size of the new flanges automatically.

3. Height

Height of the plate

4. Width

Width of the plate

5. Projection 1

Projection at one flange edge. Negative values are permitted.

6. Projection 2

Projection at the other flange edge. Negative values are permitted.

Create weld

The plate will be welded to the beam by fillet weld, thickness 4 mm. You can modify the properties of the weld in the properties dialog box of the weld.

The Autodesk Advance Steel properties of the plate are partially greyed out because they are controlled by the properties of the intelligent brick (see above).

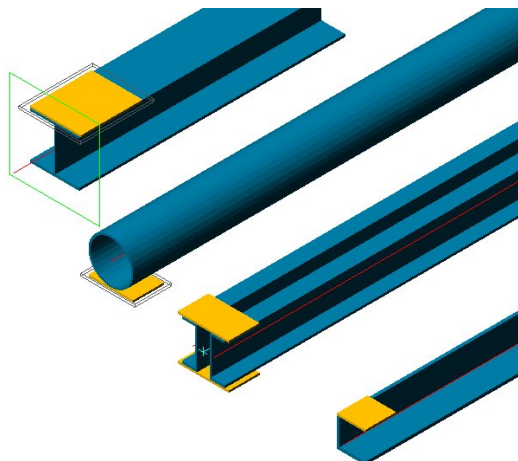

Plate parallel beam flange

This intelligent brick adds up to four plates at the edges of the flanges of an existing beam. The thickness of the plate protrudes never beyond the top or the bottom flange.

The orientation of the beam is irrelevant. The beam can also be part of a structural element and can already have features and connecting elements.

Due to the internal coordinate system, generated during the creation of each beam in Advance Steel, all beams have flanges, even pipes. Hence, this brick can be used for pipes, too.

The plate can be added parallel or perpendicular to the flange



The size of the plate can be defined by length and width. With the definition of an offset you can create an intelligent relation to the end of the beam.

Example:

Click "**Plate parallel beam flange**" from tool palette, category "**Custom Connection**".

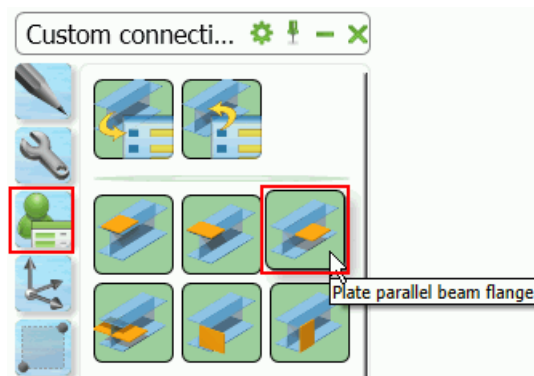

Select beam

Select the beam at one end.

The command stopped automatically and the plate is added at this end of the beam, which is closest to the selected point.

The plate is surrounded by a grey box, so that you can see in the model that the plate is not just a common plate.

If you want to open this properties dialog box later again, please select the plate or the grey box, right click and choose from the context menu "**Advance Joint Properties**".

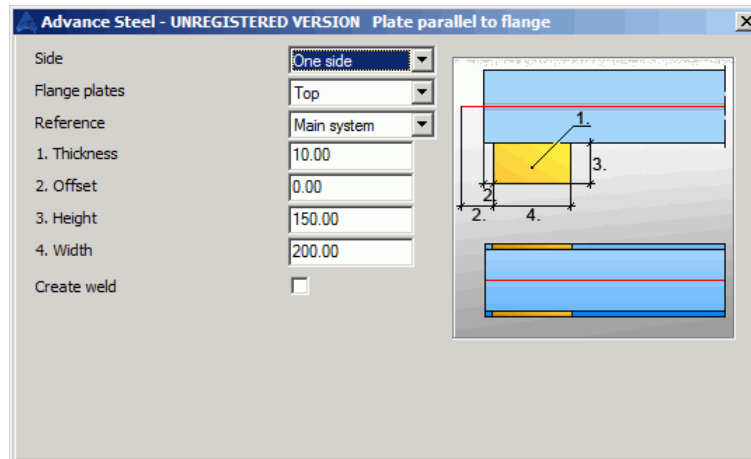

- Side** You can define if one plate is added to one edged of one flange or to the other edge of the flange, or if one plate is added to each edge of the flange.
- Flange plates** You can define if the plate/ plates is/are added to the upper or the lower flange or to both flanges.
- Reference** This option is set to **"Main system"** by default. This means that the plate will always be added to the end of the system line. If the beam already has a shortening, the plate is not entirely on the beam. With **"Main physical"** the plate will be moved to the physical end of the beam. So, if you have to modify the value of the feature later, the plate will move to the new end of the beam automatically.
- 1. Thickness** Thickness of the plate.
- 2. Offset** Distance of the plate from the physical end of the beam. Here you can define an intelligent relation to the end of the beam.
- 3. Height** Height of the plate
- 4. Width** Width of the plate
- Create weld** The plate will be welded to the beam by fillet weld, thickness 4 mm. You can modify the properties of the weld in the properties dialog box of the weld.

The Autodesk Advance Steel properties of the plate are partially greyed out because they are controlled by the properties of the intelligent brick (see above).

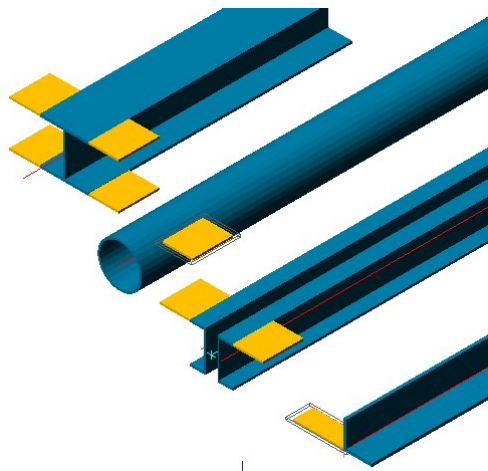

Plate along beam web

This intelligent brick adds up to two plates at the web of an existing beam in the direction of the system line.

The orientation of the beam is irrelevant. The beam can also be part of a structural element and can already have features and connecting elements.

Due to the internal coordinate system, generated during the creation of each beam in Advance Steel, all beams have flanges, even pipes. Hence, this brick can be used for pipes, too.

The plate can be added parallel or perpendicular to the web.

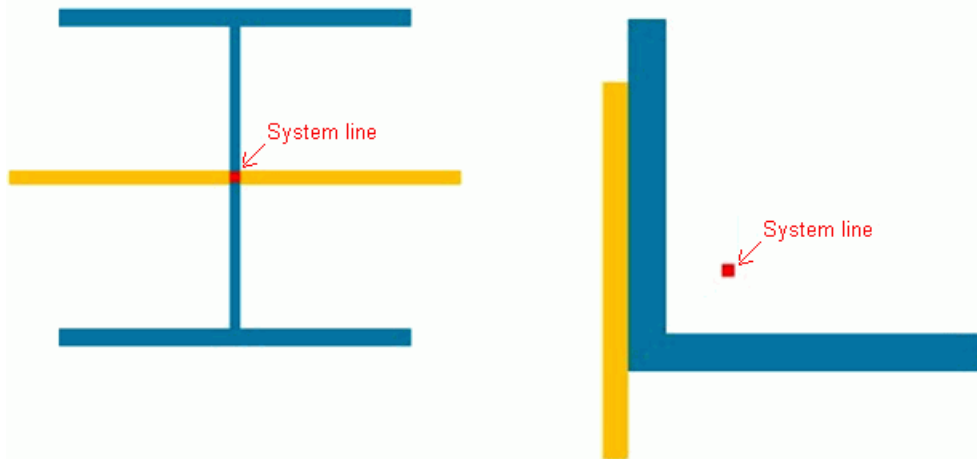

The size of the plate can be defined by length and width or for plates, which are parallel to the web, by projections, so the size of the plate can have an intelligent relation to the height of the web. By defining an offset, it is possible to create an intelligent relation to the end of the beam.

Example:

Click "**Plate along beam web**" from tool palette, category "**Custom Connection**".



Select beam

Select the beam at one end.

The command stopped automatically and the plate is added at this end of the beam, which is closest to the selected point.

The plate is surrounded by a grey box, so that you can see in the model that the plate is not just a common plate.

If you want to open this properties dialog box later again, please select the plate or the grey box, right click and choose from the context menu "**Advance Joint Properties**".

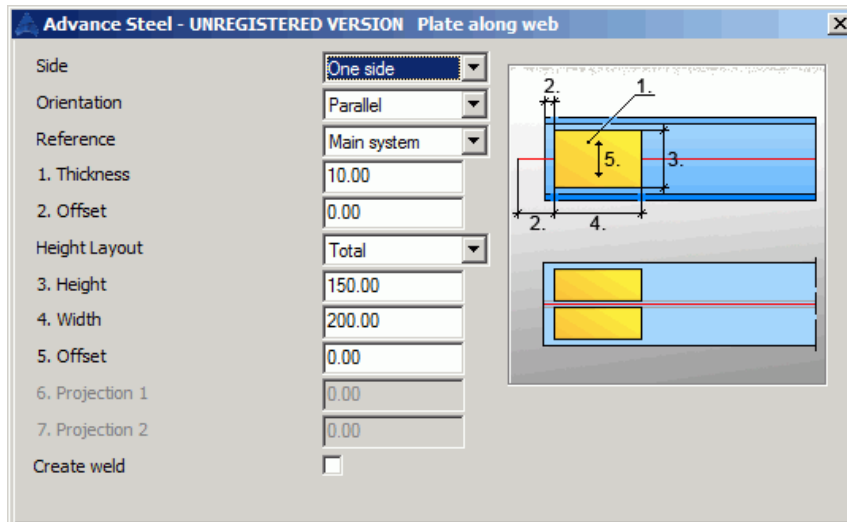

- Side** You can define if one plate is added to one side of the web or to the other side of the web, or if two plates are added, each one at each side of the web.
- Orientation** You can set the plate / the plates parallel or perpendicular to the web.
- Reference** This option is set to "**Main system**" by default. This means, that the plate will always be added to the end of the system line. If the beam already has a shortening, the plate is not entirely on the beam. With "**Main physical**" the plate will be moved to the physical end of the beam. So if you have to modify the value of the feature later, the plate will move to the new end of the beam automatically
- 1. Thickness** Thickness of the plate.
- 2. Offset** Distance of the plate from the physical end of the beam. Here you can define an intelligent relation to the end of the beam.
- Height Layout** Here you can distinguish how the width of the plate will be defined. For the option "**Total**" the value "**4. Width**" is used. With the option "**Projection**" the values "**6. Projection 1**" and "**7. Projection 2**" are used. If you modify the size of the beam later, the size of the plate will be adapted to the size of the new web automatically.
- 3. Height** Height of the plate.
- 4. Width** Width of the plate.
- 5. Offset** Here you can define the offset of the plate transverse to the direction of the beam.
- 6. Projection 1** Projection at one flange.
- 7. Projection 2** Projection at the other flange.
- Create weld** The plate will be welded to the beam by fillet weld, thickness 4 mm. You can modify the properties of the weld in the properties dialog box of the weld.

The Autodesk Advance Steel properties of the plate are partially greyed out because they are controlled by the properties of the intelligent brick (see above).

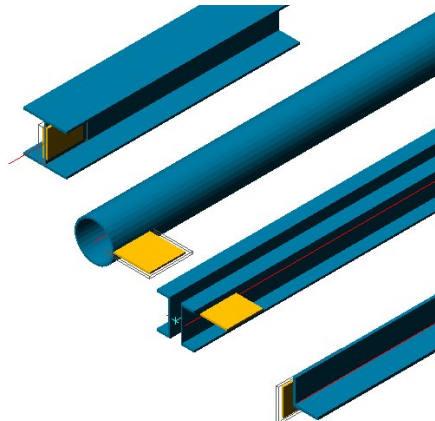

Plate on beam web

This intelligent brick adds up to two plates at the web of an existing beam crosswise to the system line.

The orientation of the beam is irrelevant. The beam can also be part of a structural element and can already have features and connecting elements.

Due to the internal coordinate system, generated during the creation of each beam in Advance Steel, all beams have flanges, even pipes. Hence, this brick can be used for pipes, too.



The size of the plate can be defined by length and width or for plates, which are parallel to the web, by projections, so the size of the plate can have an intelligent relation to the height of the web. By defining an offset, it is possible to create an intelligent relation to the end of the beam.

Example:

Click "**Plate on beam web**" from tool palette, category "**Custom Connection**".

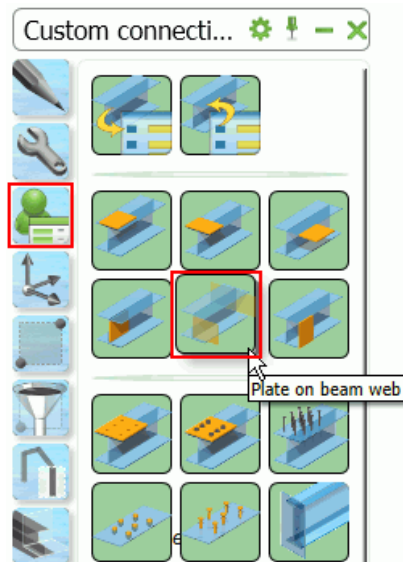

Select beam

Select the beam at one end.

The command stopped automatically and the plate is added at this end of the beam, which is closest to the selected point.

The plate is surrounded by a grey box, so that you can see in the model that the plate is not just a common plate.

If you want to open this properties dialog box later again, please select the plate or the grey box, right click and choose from the context menu "**Advance Joint Properties**".

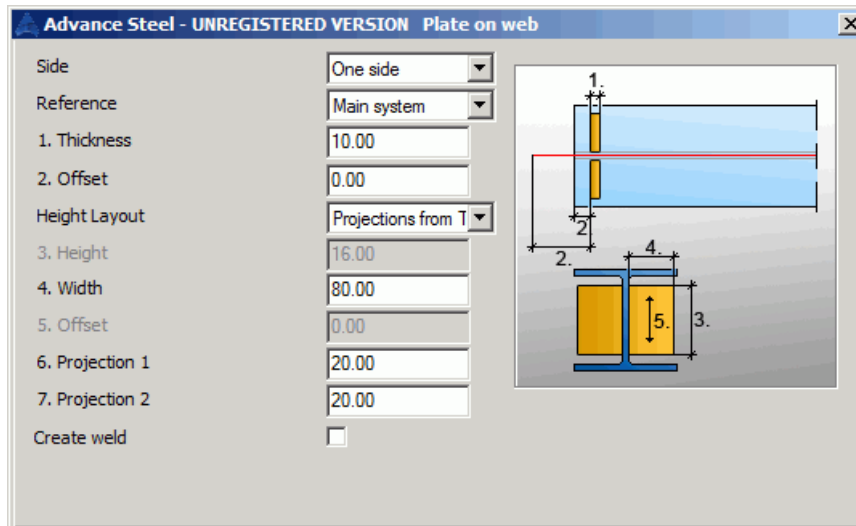

- Side** You can define if one plate is added to one side of the web or to the other side of the web, or if two plates are added, each one at each side of the web.
- Reference** This option is set to **"Main system"** by default. This means, that the plate will always be added to the end of the system line. If the beam already has a shortening, the plate is not entirely on the beam. With **"Main physical"** the plate will be moved to the physical end of the beam. So if you have to modify the value of the feature later, the plate will move to the new end of the beam automatically.
- 1. Thickness** Thickness of the plate.
- 2. Offset** Distance of the plate from the physical end of the beam. Here you can define an intelligent relation to the end of the beam.
- Height Layout** Here you can choose how the height of the plate will be defined. With the setting **"Total width"** the value **"3. Height"** is used. With the setting **"Projections"** values **"6. Projection 1"** and **"7. Projection 2"** are used. If you modify the size of the beam later, the size of the plate will be adapted to the size of the new web automatically.
- 3. Height** Height of the plate.
- 4. Width** Width of the plate.
- 5. Offset** Here you can define the offset of the plate transverse to the direction of the beam.
- 6. Projection 1** Projection at one flange.
- 7. Projection 2** Projection at the other flange.
- Create weld** The plate will be welded to the beam by fillet weld, thickness 4 mm. You can modify the properties of the weld in the properties dialog box of the weld.

The Autodesk Advance Steel properties of the plate are partially greyed out because they are controlled by the properties of the intelligent brick (see above).

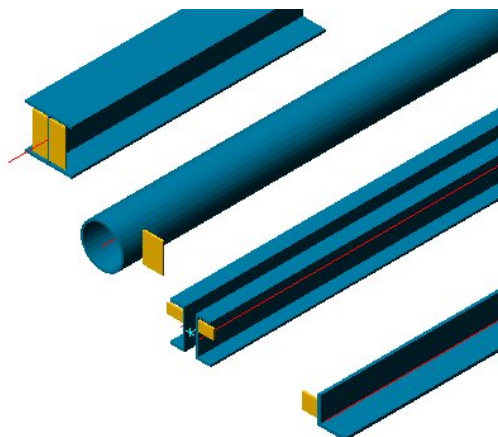
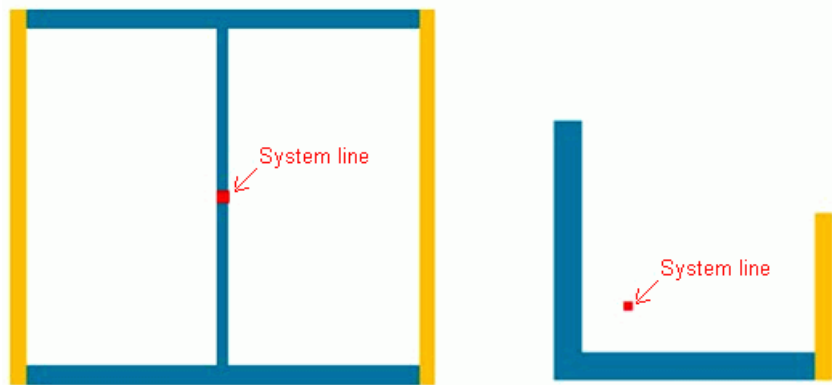

Plate parallel beam web

This intelligent brick adds up to two plates at the edges of the flanges of an existing beam parallel to the web.

The orientation of the beam is irrelevant. The beam can also be part of a structural element and can already have features and connecting elements.

Due to the internal coordinate system, generated during the creation of each beam in Advance Steel, all beams have flanges, even pipes. Hence, this brick can be used for pipes, too.



The size of the plate can be defined by length and width or for plates, which are parallel to the web, by projections, so the size of the plate can have an intelligent relation to the height of the web. By defining an offset, it is possible to create an intelligent relation to the end of the beam.

Example:

Click "**Plate parallel beam web**" from tool palette, category "**Custom Connection**".

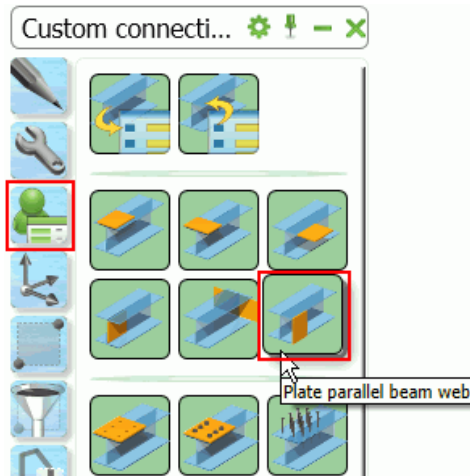

Select beam

Select the beam at one end.

The command stopped automatically and the plate is added at this end of the beam, which is closest to the selected point.

The plate is surrounded by a grey box, so that you can see in the model that the plate is not just a common plate.

If you want to open this properties dialog box later again, please select the plate or the grey box, right click and choose from the context menu "**Advance Joint Properties**".

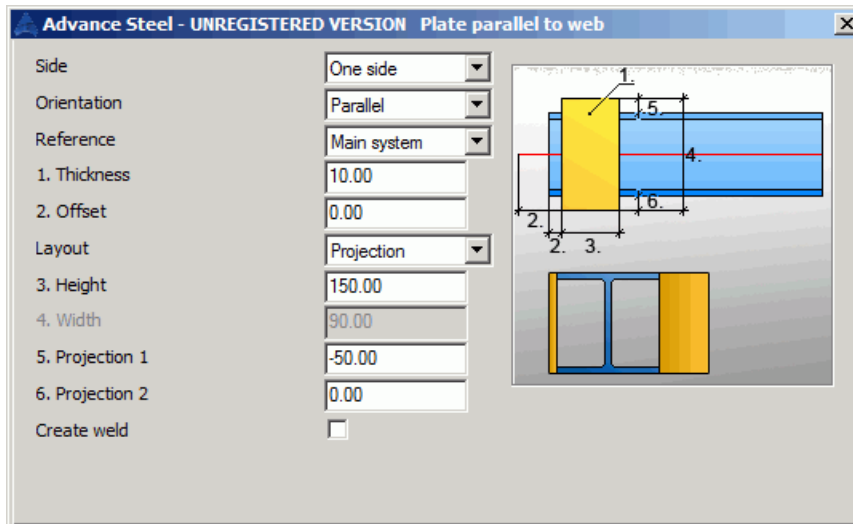

- Side** You can define if one plate is added to one edged of one flange or to the other edge of the flange, or if one plate is added to each edge of the flange.
- Orientation** You can define if the plate(s) is / are added parallel or perpendicular to the web.
- Reference** This option is set to "**Main system**" by default. This means, that the plate will always be added to the end of the system line. If the beam already has a shortening, the plate is not entirely on the beam. With "**Main physical**" the plate will be moved to the physical end of the beam. So if you have to modify the value of the feature later, the plate will move to the new end of the beam automatically.
- 1. Thickness** Thickness of the plate.
- 2. Offset** Distance of the plate from the physical end of the beam. Here you can define an intelligent relation to the end of the beam.
- Layout** Defines how the size of the plate is set. With the setting "**Total**" the value "**4. Width**" will be defined as total width. W the setting "**Projections**" values "**5. Projection 1**" and "**6. Projection 2**" are used. If you modify the size of the beam later, the size of the plate will be adapted to the size of the new web automatically.
- 3. Height** Height of the plate.
- 4. Width** Width of the plate.
- 5. Projection 1** Projection at one flange.
- 6. Projection 2** Projection at the other flange.
- Create weld** The plate will be welded to the beam by fillet weld, thickness 4 mm. You can modify the properties of the weld in the properties dialog box of the weld.

The Autodesk Advance Steel properties of the plate are partially greyed out because they are controlled by the properties of the intelligent brick (see above).

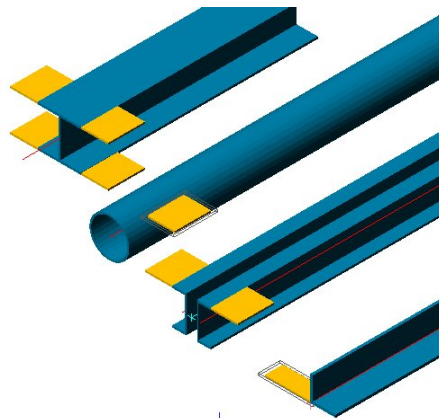

Bolts on beam

This intelligent brick adds any type of bolts, holes or anchors in the flanges or the web of an existing beam. The orientation of the beam is irrelevant. The beam can also be part of a structural element and can already have features and connecting elements.

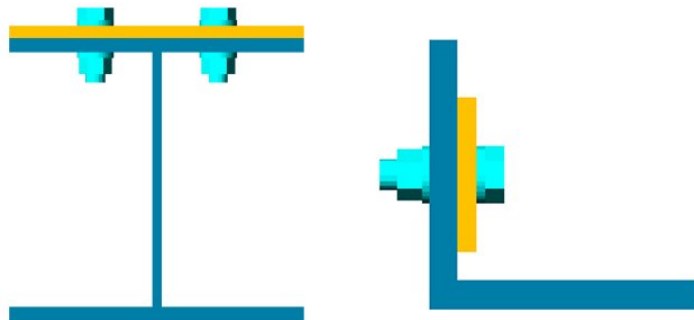

The connecting elements depend always on a beam. But during the creation you can select further elements which should be connected. Here you can select beams and plates. It is possible to create an intelligent relation between the connecting elements and the end of the beam.

Example:

Click "**Bolts on beam**" from tool palette, category "**Custom Connection**".



Select beam

Select the beam at one of its ends.

Select connecting objects? <Yes/No>

If you enter "y" for "yes", then you will be asked to select further elements.

Select objects to be connected

Select elements:

Now you can select further elements one by one using left click, finish your selection by right click.

If you want to select no further elements (e.g. if you want to insert holes), the user must enter "n" for "no" and finish the command by Enter. The command stopped and the properties window appears.

The bolts are added at the end of the beam which is closest to the selected point.

The inserted bolts are surrounded by a grey box, so that you can see in the model that the bolts are not only common bolts.

If you want to open this properties dialog box later again, please select one of the bolts or the grey box, right click and choose from the context menu "**Advance Joint Properties**".

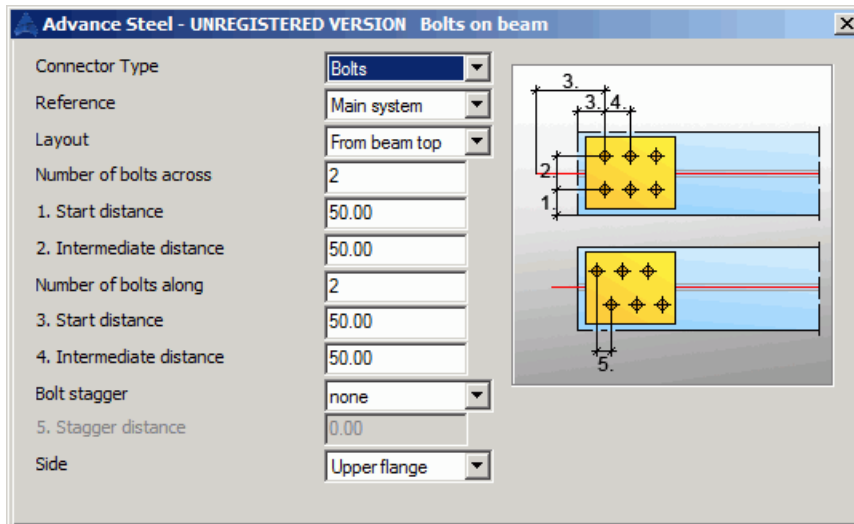
**Connector Type**

Here you can define if you want to add bolts, anchors or holes.

Reference

This option is set to **"Main system"** by default. This means that the bolts will always be added to the end of the system line. If the beam already has a shortening, the bolts may pass the end of the beam. With **"Main physical"** the bolts will be moved to the physical end of the beam. So if you have to modify the value of the feature later, the bolts will be moved to the new end of the beam automatically.

Layout

Here you can define if the bolt position is measured from the edge of the beam with **"From beam top"** or if the bolts should be added **"centred"** at the beam.

Number of bolts across

Number of bolts across the beam.

1. Start distance

Distance to the edge of the beam.

2. Intermediate distance

Distance between the bolts traverse across the beam.

Number of bolts along

Number of bolts along the beam.

3. Start distance

Distance to the end of the beam. Depending on the setting of option **"Reference"** the value refers to the system line or the end of the beam.

4. Intermediate distance

Distance between the bolts along the beam.

Bolt stagger

If you add two rows of bolts you can move one row in relation to the other row.

5. Stagger distance

Value of stagger

Side

Here you can define if the bolts will be added into the upper or the lower flange or into the web.

Within this properties dialog box you can define the position and the type (bolts, anchors or holes) of the connecting elements. Further properties of the connecting elements can be defined in the Autodesk Advance Steel Properties Dialog Box of the connecting elements. Therefore you have to select e.g. one bolt, right click and select "**Advance Steel Properties**" from the context menu. Now you are able to set the properties of the bolts as usual.

To modify the properties of holes, it is necessary to switch the display type of the beam to "**Features**" to make the green symbol visible that represents the hole. Now you can select the green symbol, right click and select "**Advance Steel Properties**" from the context menu. The "**Hole pattern**" dialog box appears and you can modify the properties of the holes as usual.

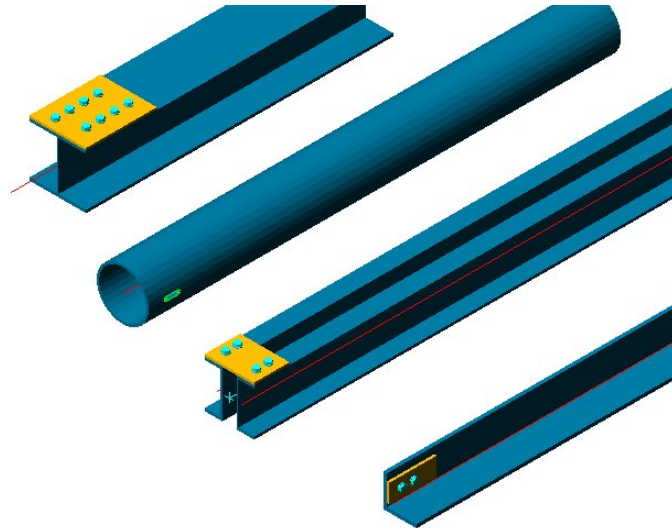

Bolts on gauge line

This intelligent brick adds any type of bolts, holes or anchors on gauge lines of an existing beam. The orientation of the beam is irrelevant. The beam can also be part of a structural element and can already have features and connecting elements.

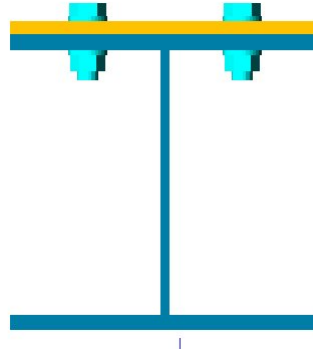

The connecting elements depend always on a beam. But during the creation you can select further elements which should be connected. Here you can select beams and plates. It is possible to create an intelligent relation between the connecting elements and the end of the beam.

Example:

Click "**Bolts on beam gauge line**" from tool palette, category "**Custom Connection**".

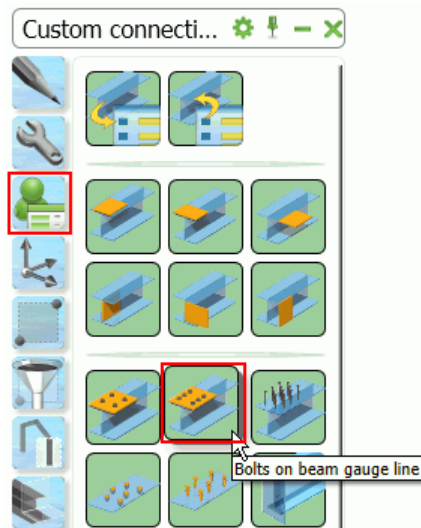

Select beam

Select the beam at one of its ends.

Select connecting objects? <Yes/No>

If you enter "y" for "yes", then you will be asked to select further elements.

Select objects to be connected

Select elements:

Now you can select further elements one after one by left click, finish your selection by right click.

If you want to select no further elements (e.g. if you want to insert holes), the user must enter "n" for "no" and finish the command by Enter. The command stopped and the properties window appears.

The bolts are added at the closest end of the beam.

The bolts are surrounded by a grey box, so that you can see in the model that the bolts are not only common bolts.

If you want to open this properties dialog box later again, please select one of the bolts or the grey box, right click and choose from the context menu "**Advance Joint Properties**".

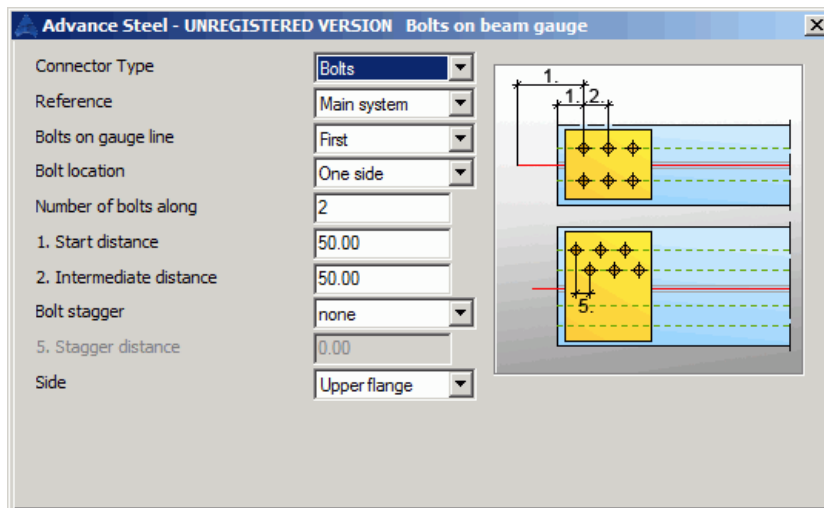
**Connector Type**

Here you can define if you want to add bolts, anchors or holes.

Reference

This option is set to **"Main system"** by default. This means that the bolts will always be added to the end of the system line. If the beam already has a shortening, the bolts may pass the end of the beam. With **"Main physical"** the bolts will be moved to the physical end of the beam. So if you have to modify the value of the feature later, the bolts will be moved to the new end of the beam automatically.

Bolts on gauge line

Setting for profiles with more than one gauge line at one flange.

Bolt location

Here you can define which side of the web the bolts should be added to (one side, other side or both sides).

1. Start distance

Distance to end of beam.

2. Intermediate distance

Distance between the bolts along the beam.

Bolt stagger

If you add two rows of bolts you can move one row in relation to the other row.

5. Stagger distance

Value of stagger

Side

Here you can define if the bolts will be added into the upper or the lower flange or into the web.

Within this properties dialog box you can define the position and the type (bolts, anchors or holes) of the connecting elements. Further properties of the connecting elements can be defined in the Autodesk Advance Steel Properties Dialog Box of the connecting elements. Therefore you have to select e.g. one bolt, right click and select **"Advance Steel Properties"** from the context menu. Now you are able to set the properties of the bolts as usual.

To modify the properties of bolts, it is necessary to switch the display type of the beam to **"Features"** to make the green symbol visible that represents the hole. Now you can select the green symbol, right click and select **"Advacne Steel Properties"** from the context menu. The **"Hole pattern"** dialog box appears and you can modify the properties of the holes as usual.

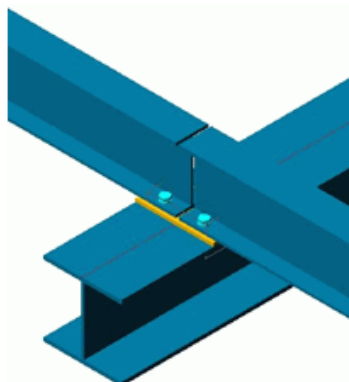

Studs on beam

This intelligent brick adds shear studs at an existing beam. The orientation of the beam is irrelevant. The beam can also be part of a structural element and can already have features and connecting elements.

The shear studs will be welded to the beam with a fillet weld, thickness 4 mm. You are able to modify the properties of the weld in the "Advance Steel Properties" of the weld.

It is possible to create an intelligent relation between the shear studs and the end of the beam.

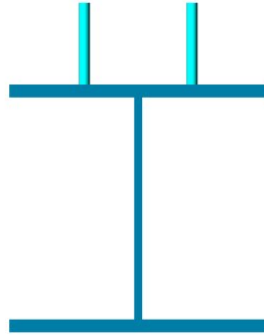

Example:

Click "Studs on beam" from tool palette, category "**Custom Connection**".

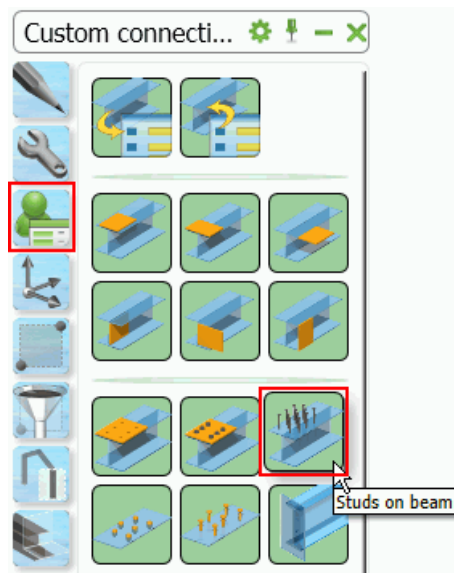

Select beam

Select the beam at one of its ends.

The command stopped automatically and the shear studs are added at this end of the beam, which is closest to the selected point.

The shear studs are surrounded by a grey box, so that you can see in the model that the shear studs are not only common parts.

If you want to open this properties dialog box later again, please select one of the shear studs or the grey box, right click and choose from the context menu "**Advance Joint Properties**".

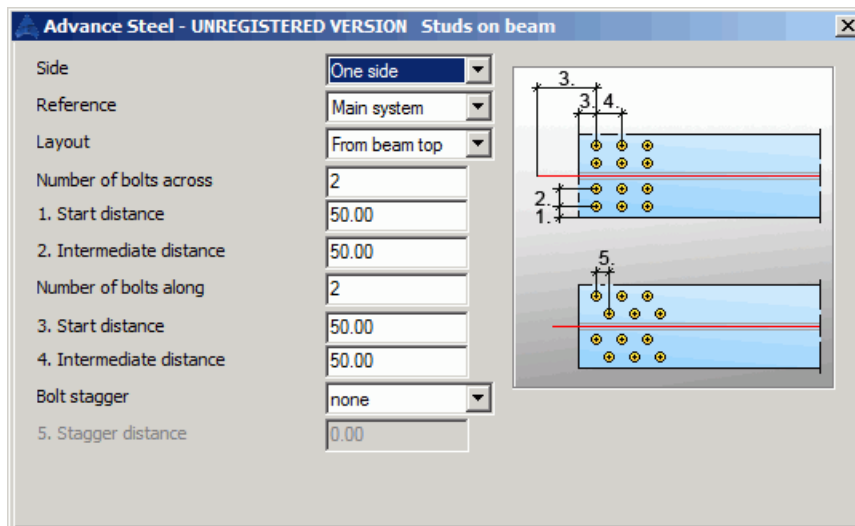

- Side** Here you can define if the shear studs will be added into the upper or the lower flange or into both flanges.
- Reference** This option is set to **"Main system"** by default. This means, that the shear studs will always be added to the end of the system line. If the beam already has a shortening, the shear studs may pass the end of the beam. With **"Main physical"** the shear studs will be moved to the physical end of the beam. So if you have to modify the value of the feature later, the shear studs will be moved to the new end of the beam automatically.
- Layout** Here you can define if the shear studs should be positioned from the edge of the beam with **"From beam top"** or if the shear studs should be added **"centred"** on the beam.
- Number of bolts across** Number of shear studs across the beam.
- 1. Start distance** Distance to the edge of the beam.
- 2. Intermediate distance** Distance between the shear studs across the beam.
- Number of bolts along** Number of shear studs along the beam.
- 3. Start distance** Distance to the end of the beam. Depending on the setting of option **"Reference"**, the value refers to the system line or the end of the beam. It is possible to create an intelligent relation to the end of the beam here.
- 4. Intermediate distance** Distance between the shear studs along the beam.
- Bolt stagger** If you add two rows of shear studs you can move one row in relation to the other row.
- 5. Stagger distance** Value of stagger

Within this properties dialog box you can define the position of the shear studs. Further properties of the shear studs can be defined in the Autodesk Advance Steel Properties Dialog Box of the shear studs. Therefore you have to select e.g. one shear stud, right click and select **"Advance Steel Properties"** from the context menu. Now you are able to set the properties of the shear studs as usual.

Bolts/Anchors/Holes on plate

This intelligent brick adds any type of bolts, holes or anchors into an existing plate. The orientation of the plate is irrelevant. The plate can also be part of an automatic joint and can already have features and connecting elements.

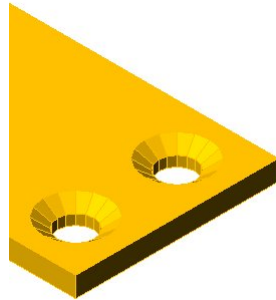

The connecting elements depend always on a plate. During the creation you can select further elements, but you can select other plates only. By defining projections you can create an intelligent relation to the size of the main plate.

Example:

Click "**Bolts/Anchors/Holes on plate**" from tool palette, category "**Custom Connection**".

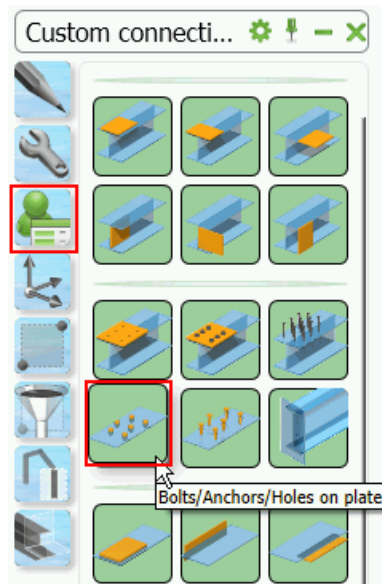

Select main plate

Select elements:

Select the main plate and finish your selection by right click.

Select connecting objects

Select elements:

Select further plates by left click and finish your selection by right click.

If you don't want to add further plates (e.g. if you want to add holes), finish the command by right click. The command stops and the properties dialog box appears.

The connecting elements will be added.

They are surrounded by a grey box, so that you can see in the model that they are not only common parts.

If you want to open this properties dialog box later again, please select one of the connecting elements or the grey box, right click and choose from the context menu "**Advance Joint Properties**".

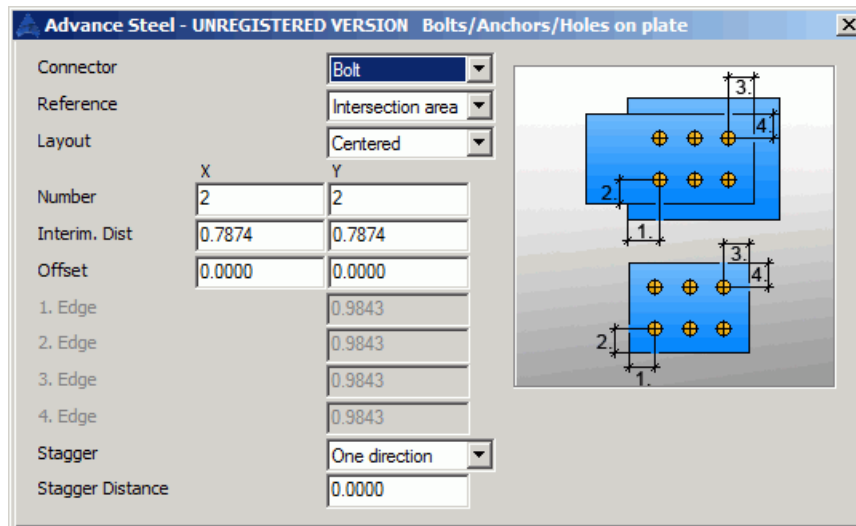
**Connector**

Here you can define if you want to add bolts, anchors or holes.

Reference

Here you can specify where the values refer to for edge distances. If you select "**plate**", then the values refer to the edges of the main plate, if you select "**Intersection area**" then the values refer to the edges of the area which is covered by all plates which are included in the connection.

Layout

Here you can define if all connecting elements should be arranged centred on the plates (all fields for edge distances are greyed out then) or if you want to set edge distances for the connecting elements.

Number x / y

Number of connecting elements in the x- and y- direction of the UCS of the main plate.

Interim. Dist.

Distance between the connecting elements in the x- and y- direction of the UCS of the main plate.

Offset

If you have selected "**Centered**" you can move the connecting elements with this setting in x- and y- direction of the UCS of the main plate out of the centre.

1.-4. Edge

Edge distances

Stagger

If you add two rows of bolts you can move one row in relation to the other row.

Stagger Distance

Value of stagger

Within this properties dialog box you can define the position and the type (bolts, anchors or holes) of the connecting elements. Further properties of the connecting elements can be defined in the Autodesk Advance Steel Properties Dialog Box of the connecting elements. Therefore you have to select e.g. one bolt, right click and select "**Advance Steel Properties**" from the context menu. Now you are able to set the properties of the bolts as usual. Here all elements in y- direction are summarized.

To modify the properties of holes, it is necessary to switch the display type of the plate to "**Features**" to make the green symbol visible that shows the hole. Now you can select the green symbol, right click and select "**Advacne Steel Properties**" from the context menu. The "**Hole pattern**" dialog box appears and you can modify the properties of the holes as usual.

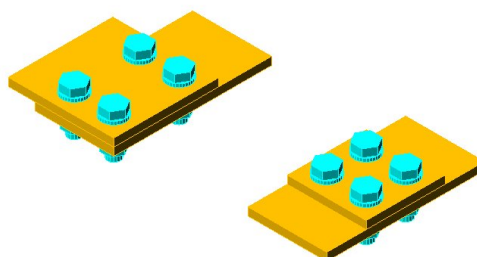

Studs on plate

This intelligent brick adds shear studs at an existing plate. The orientation of the plate is irrelevant. The head of the shear stud is always in positive z- direction of the internal USC of the plate. The plate can also be part of an automatic joint and can already have features and connecting elements.

The shear stud will be welded to the plate with a fillet weld, thickness 4 mm. You are able to modify the properties of the weld in the "Advance Steel Properties" of the weld. By defining projections you can create an intelligent relation to the size of the plate.

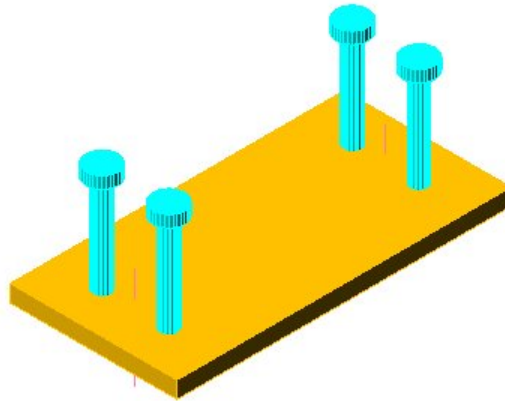

Example:

Click "**Studs on plate**" from tool palette, category "**Custom Connection**".

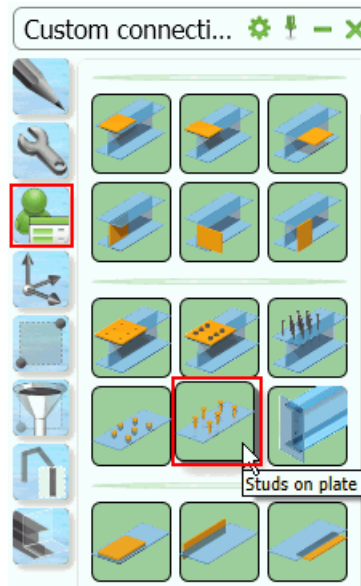

Select main plate

Select elements:

Select the plate by left click and confirm your selection by right click.

The command stopped and the shear studs are added at the plate.

The shear studs are surrounded by a grey box, so that you can see in the model that the shear studs are not only common parts.

If you want to open this properties dialog box later again, please select one of the shear studs or the grey box, right click and choose from the context menu "**Advance Joint Properties**".

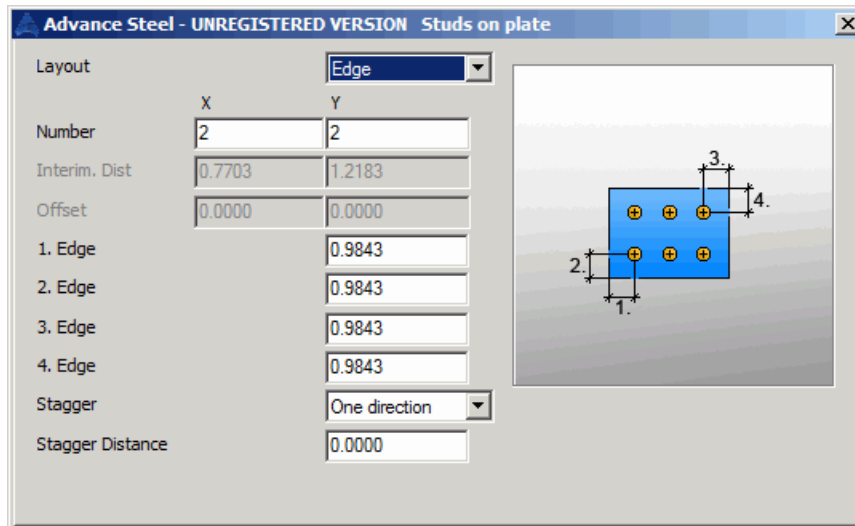
**Layout**

Here you can define if all shear studs should be arranged centred on the plates (all fields for edge distances are greyed out then) or if you want to set edge distances for the shear studs.

Number x / y

Number of shear studs in the x- and y- direction of the UCS of the main plate.

Interim. Dist.

Distance between the shear studs in the x- and y- direction of the UCS of the main plate.

Offset

If you have selected "**Centered**" you can move the shear studs with this setting in x- and y- direction of the UCS of the main plate out of the centre.

1.-4. Edge

Edge distances. Here you are able to define an intelligent relation to the size of the plate.

Stagger

If you add two rows of shear studs you can move one row in relation to the other row.

Stagger Distance

Value of stagger

Within this properties dialog box you can define the position of the shear studs. Further properties of the shear studs can be defined in the Autodesk Advance Steel Properties Dialog Box of the shear studs. Therefore you have to select one shear stud, right click and select "**Advance Steel Properties**" from the context menu. Now you are able to set the properties of the shear studs as usual.

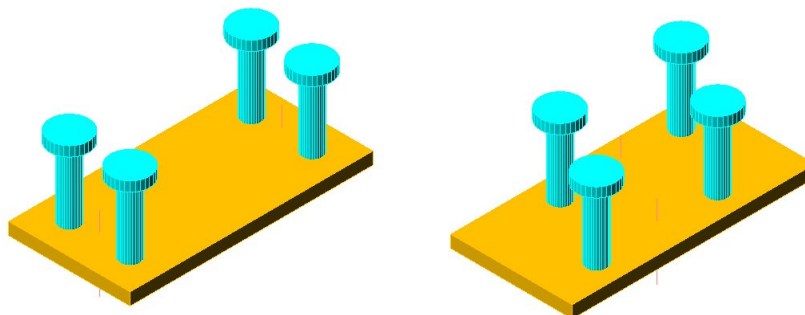

Galvanizing holes

This intelligent brick adds galvanizing holes to an assembly of a beam and a plate. The orientation of the assembly is irrelevant. Beam and plate can also be part of a structural element and / or an automatic joint and can already have features and connecting elements.

The galvanizing holed can be added to the beam or the plate of the assembly.

Depending on the setting you can create intelligent relations to the size of the beam.



Example:

Click "**Galvanizing holes**" from tool palette, category "**Custom Connection**".

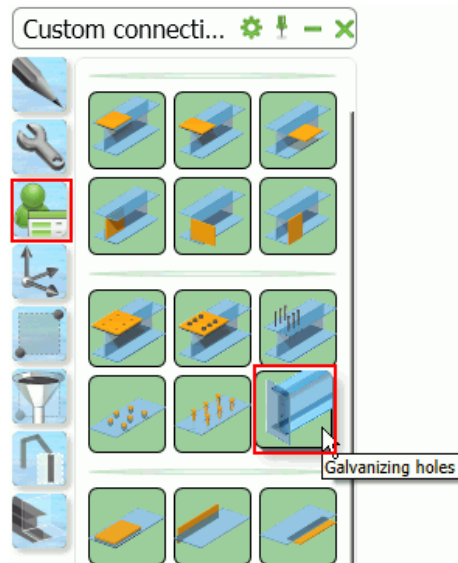

Select beam

Select elements:

Select the beam and confirm your selection by right click.

Select plate

Select elements:

Select the plate and confirm your selection by right click.

The command stopped and 4 galvanizing holes which are surrounded by a grey box, so that you can see in the model that the holes are not only common parts, are added.

If you want to open this properties dialog box later again, please select one hole or the grey box, right click and choose from the context menu "**Advance Joint Properties**".

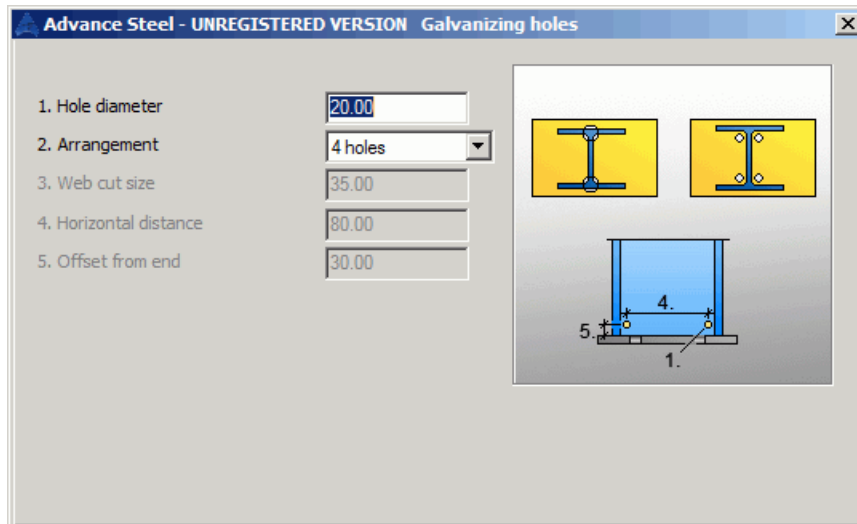

1. Hole diameter

Here you can define the diameter of the holes.

2. Arrangement

Here you can specify, if the command should add 4 holes into the plate, 3 holes centred into the plate, 2 holes transverse to the beam, 2 holes into the web or if it should add a feature to the web of the beam.

3. Web cut size

If you chose "Web cut" in option **2. Arrangement**, then this value will be activated and you can enter the size of the Web cut here.

4. Horizontal distance

If you chose "Web holes" in option **2. Arrangement**, then this value will be activated and you can enter the horizontal distance of the holes in the web here.

5. Offset from end

If you chose "Web holes" in option **2. Arrangement**, then this value will be activated and you can enter the vertical distance of the holes from the end of the web here.

You can open the properties dialog box of this intelligent brick by selecting a galvanizing hole or the feature, right click and select "**Advance Joint Properties**," from the context menu. To be able to select the symbol of the feature or of the hole, you have to select "Features" as display type for the beam or the plate first.

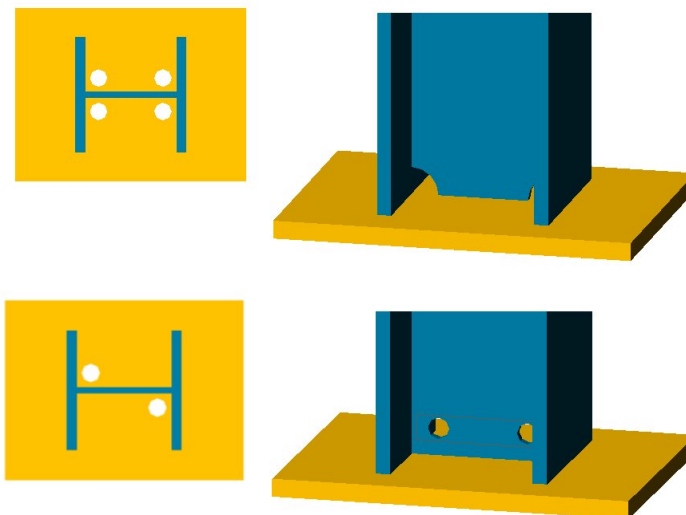
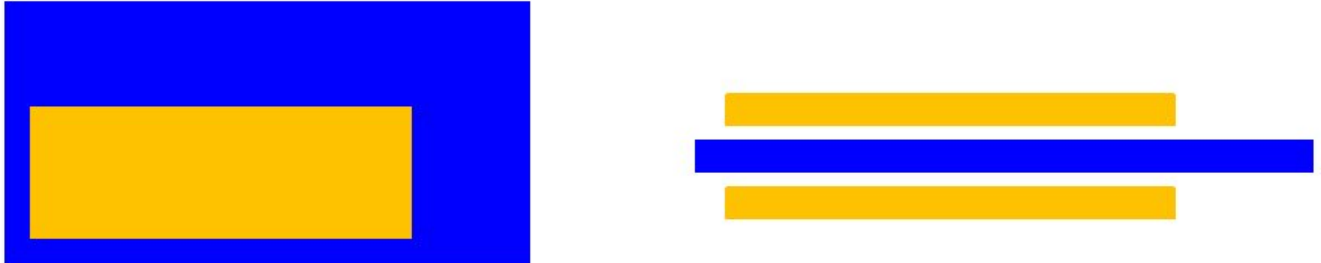

Plate on plate

This intelligent brick adds up to two plates at an existing plate. The orientation of the plate is irrelevant. The plate can also be part of an automatic joint and can already have features and connecting elements.

Depending on the settings you can create an intelligent relation to the sizes of the plates.



Example:

Click "**Plate on plate**" from tool palette, category "**Custom Connection**".



Select plate

Select elements:

Select the plate and confirm your selection by right click.

The command stopped and the new plate is added to the existing plate.

The new plate is surrounded by a grey box, so that you can see in the model that the plate is not just a common plate.

If you want to open this properties dialog box later again, please select the plate or the grey box, right click and choose from the context menu "**Advance Joint Properties**".

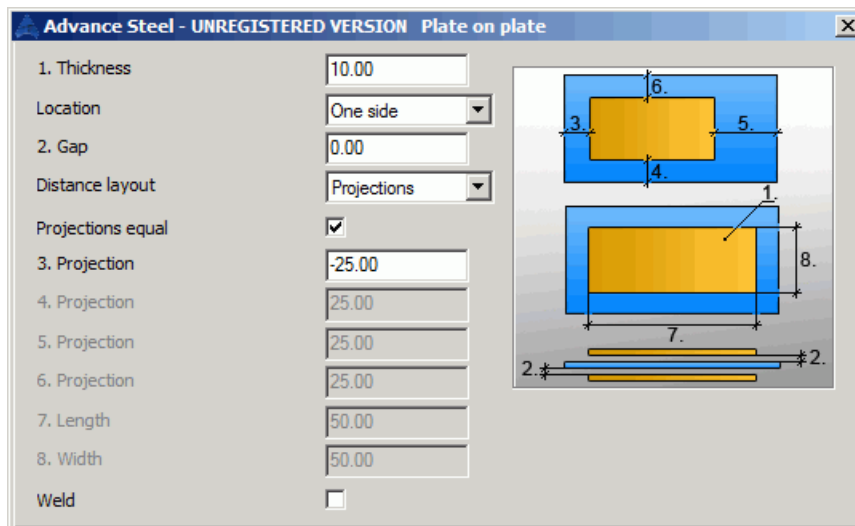
**1. Thickness**

Thickness of the plate.

Location

Here you can define if you want to add one plate at one side or one plate at the other side or if you want to add one plate at each side of the existing plate.

2. Gap

Here you can specify a gap between the existing plate and the new plate(s).

Distance layout

Here you can specify if you want to set the size of the plate(s) by total height and total width or if you want to set it by distances to the edges of the existing plate.

Projections equal

This box will be activated, if you set the option "Projections" in field **Distance layout**. If you activate this box, only one field "Projection" is active. So the size of the new plate(s) depends on the size of the existing plate.

3. – 6. Projection

These fields will be active, if you choose "**Projections**" in option **Distance layout** and the box "Projections equal" is not active.

7. Length

Here you can enter the length of the plate, if you have set "Total" in option **Distance layout**. So the size of the new plate(s) doesn't depend on the size of the existing plate.

8. Width

Here you can enter the width of the plate, if you have set "Total" in option **Distance layout**. So the size of the new plate(s) doesn't depend on the size of the existing plate.

Weld

The plates will be weld together with a counter weld, thickness 4 mm.
You can modify the properties of the weld in its Autodesk Advance Steel **Properties**.

You can open the properties dialog box of this intelligent brick by selecting one of the new plates, right click and select "**Advance Joint Properties**" from the context menu.

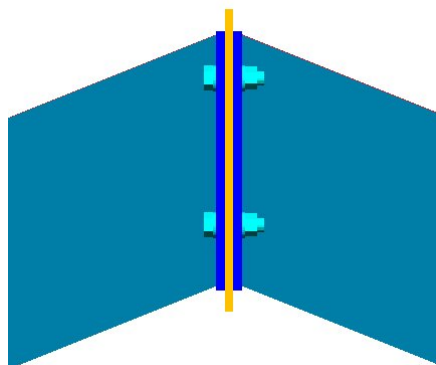
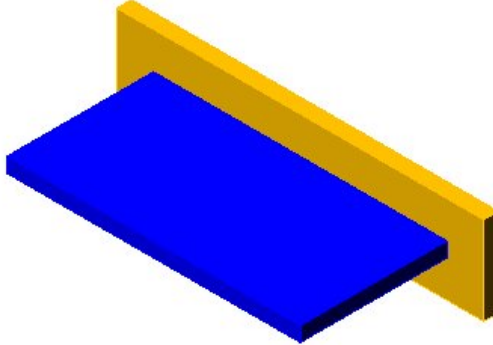

Plate perpendicular to plate

This intelligent brick adds one plate perpendicular at the edge of an existing plate. The orientation of the plate is irrelevant. The plate can also be part of an automatic joint and can already have features and connecting elements. The brick attaches the new plate on the side of the existing plate closest to the selected point.

By defining projections you can create an intelligent relation of the sizes of the plates.



Example:

Click "**Plate perpendicular to plate**" from tool palette, category "**Custom Connection**".

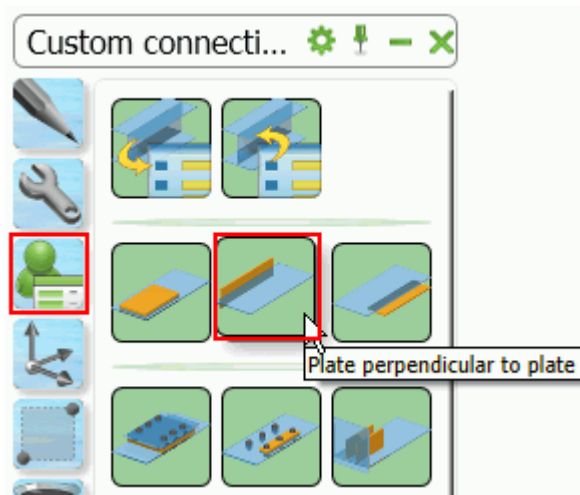

Select plate

Select elements:

Select the plate and confirm your selection by right click.

The command stopped and the plate is added to the existing plate.

The new plate is surrounded by a grey box, so that you can see in the model that the plate is not just a common plate. If you want to open this properties dialog box later again, please select the plate or the grey box, right click and choose from the context menu "**Advance Joint Properties**".

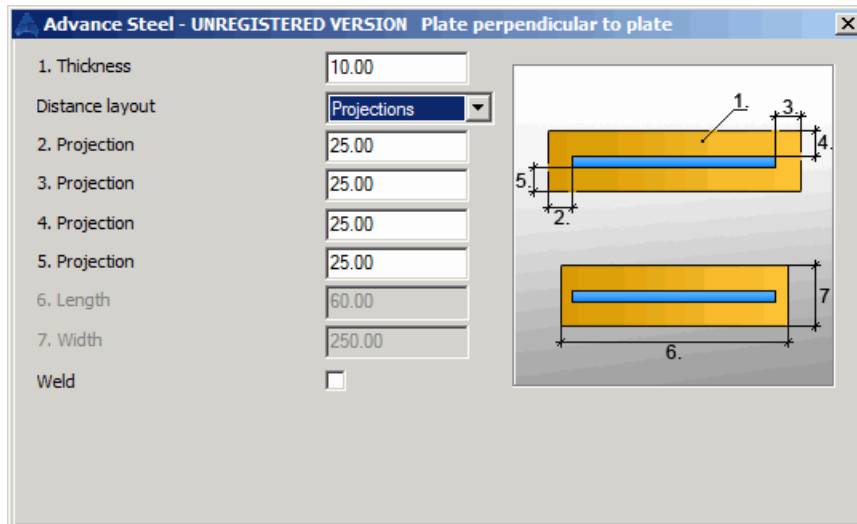

1. Thickness

Thickness of the plate.

Distance layout

Here you can specify if you want to set the size of the plate by total height and total width or if you want to set it by distances to the edges of the existing plate.

2. – 5. Projection

These fields will be active if you choose "**Projections**" in option **Distance layout** so the size of the new plate depends on the size of the existing plate.

6. Length

Here you can enter the length of the plate, if you have set "Total" in option **Distance layout**. So the size of the new plate doesn't depend on the size of the existing plate.

7. Width

Here you can enter the width of the plate, if you have set "Total" in option **Distance layout**. So the size of the new plate doesn't depend on the size of the existing plate.

Weld

The plates will be weld together with a counter weld, thickness 4 mm.
You can modify the properties of the weld in its Autodesk Advance Steel **Properties**.

You can open the properties dialog box of this intelligent brick by selecting one of the new plates, right click and select "**Advance Joint Properties**" from the context menu.

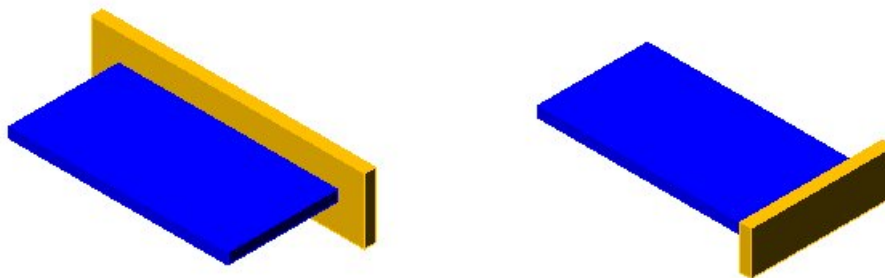
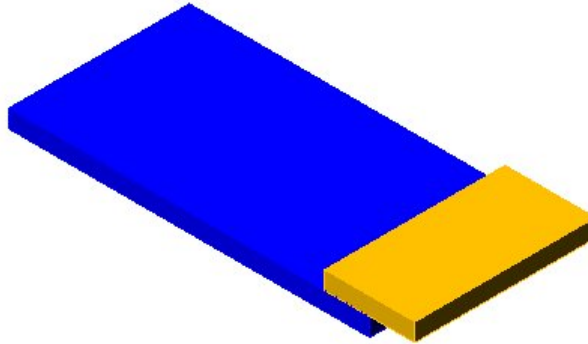

Plate at plate edge

This intelligent brick adds up to two plates at the edge of an existing plate. The orientation of the plate is irrelevant. The plate can also be part of an automatic joint and can already have features and connecting elements. The brick adds the new plate(s) always at the side of the existing plate closest to the selected point.

By defining an offset you can create an intelligent relation to the edge of the first plate.



Example:

Click "**Plate at plate edge**" from tool palette, category "**Custom Connection**".

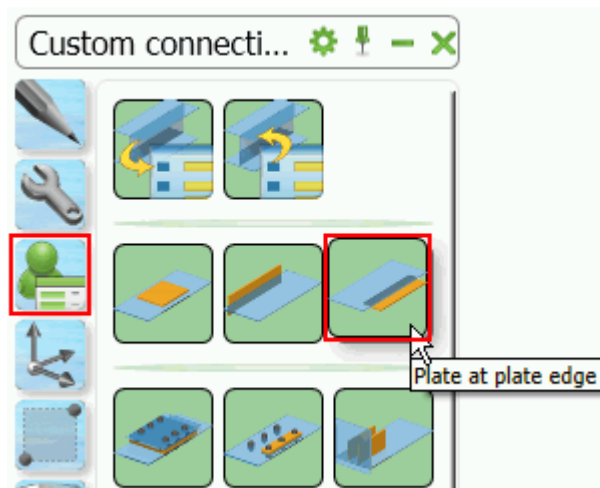

Select plate

Select the plate, the command stopped automatically and the plate is added to the existing plate.

The new plate is surrounded by a grey box, so that you can see in the model that the plate is not just a common plate.

If you want to open this properties dialog box later again, please select the plate or the grey box, right click and choose from the context menu "**Advance Joint Properties**".

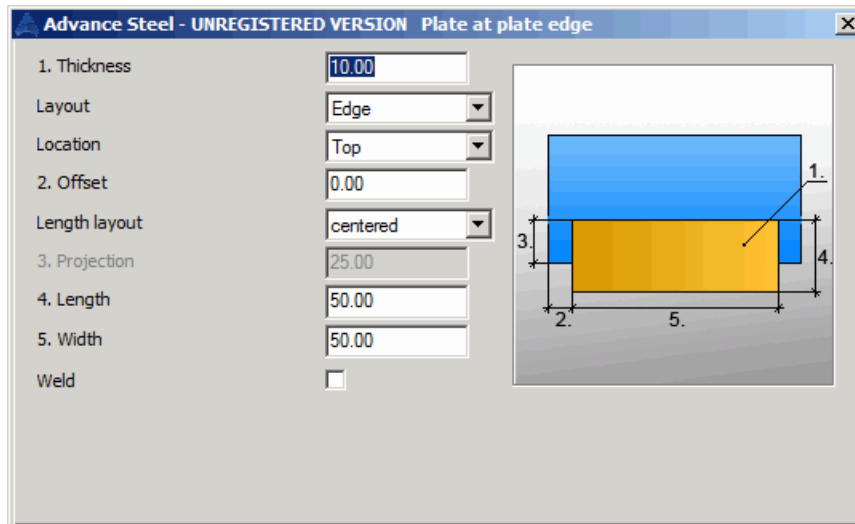

1. Thickness

Thickness of the plate.

Layout

Here you can specify if the plate should be flush at one end of the edge or flush at the other end of the edge, or if it should be centred at the edge.

Location

Here you can define, if you want to add the new plate above the existing plate (**Top**), below the existing plate (**Bottom**), if it should be planar to the existing plate (**Side**) or if you want to add one plate above and one plate below (**Top and bottoms**)

2. Offset

Here you can move the new plate by value from the position you set with option **Layout** (e.g. 10mm out of centre). So the new plate will get an intelligent relation to the edge of the first plate.

Length layout

Here you can define if the value you set with **4. Length** should be in the middle of the edge (**centered**) or if the option **3. Projection** should be used.

3. Projection

Here you can specify the distance the new and the existing plate should overlap.

4. Length

Length of the plate.

5. Width

Width of the plate.

Weld

The plates will be weld together with a counter weld, thickness 0.1 mm.

You can modify the properties of the weld in its Autodesk Advance Steel **Properties**.

You can open the properties dialog box of this intelligent brick by selecting one of the new plates, right click and select "**Advance Joint Properties**" from the context menu.

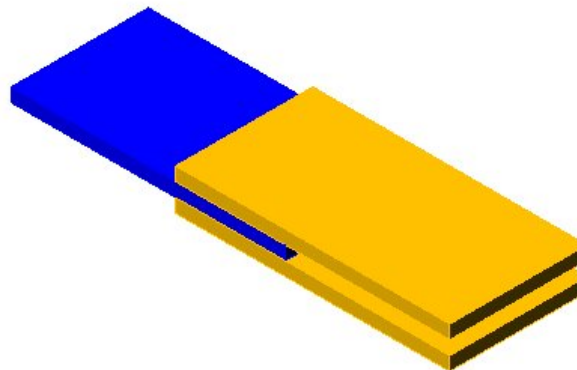

Spacer plates

This intelligent brick adds shims between existing elements, which are bolt together. The initial elements can be two plates, one plate and one beam or two beams. The orientation of the elements is irrelevant. They can also be part of an automatic joint or a structural element and can already have features and connecting elements. The brick adds four groups of shims. Within one group the thickness of the shims is the same. The number of shims in each group can be varied at will. One shim is made here of two slotted plates.

Depending on the initial elements and the settings in the Properties dialog box it is possible to create intelligent relationships.

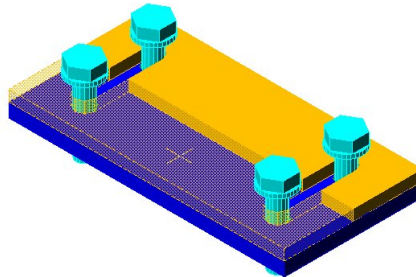

Example:

Two plates, connected with 4 bolts, gap 10 mm.

Click "**Spacer plates**" from tool palette, category "**Custom Connection**".



Select first object

Select elements:

Select the first plate by left click and confirm your selection by right click.

Select second object

Select elements:

Select the second plate by left click and confirm your selection by right click.

Select connecting object

Select elements:

Select the bolts by left click and confirm your selection by right click.

The command stopped and the shims are added.

The new plates are surrounded by a grey box, so that you can see in the model that the plates are not only common plates.

If you want to open this properties dialog box later again, please select one plate or the grey box, right click and choose from the context menu "**Advance Joint Properties**".

Hint: Four shims are always added first, one for each possible group.

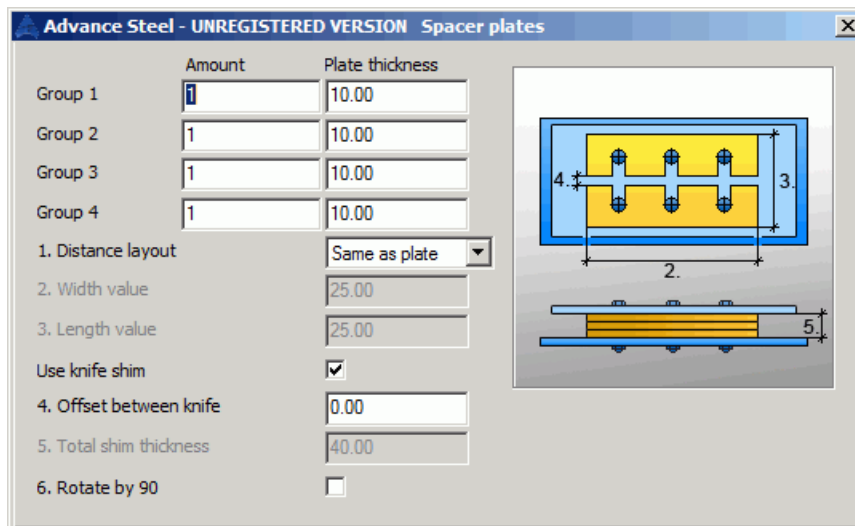
**Group 1 - 4**

Here you can specify up to four groups with different plate thickness and number.

Amount

Number of shims per group.

Plate thickness

Thickness of each shim in the group

1. Distance layout

Here you can define the size of the shims:

Same as plate -> the shims have the same size as the plate you have selected first.

Offset -> the shims size is smaller or bigger (negative value) then the size of the initial plate. You control the difference with **2. Width value** and **3. Length value**.

Value -> here you can specify with option **2. Width value** and **3. Length value** the size of the shims directly.

2. Width value

see **1. Distance layout**

3. Length value

see **1. Distance layout**

Use knife shim

If you deactivate this box each shim is made from a plate with holes.

4. Offset between knife

If the option **Use Knife Shim** is activated, you can specify a gap between the edges of the two parts of one shim here.

5. Total shim thickness

This box is always greyed out. Here you can see the accumulated thickness of all shims.

6. Rotate by 90°

The shims are rotated in their position by 90°. This has mainly effects to the course of the slots in the plates.

You can open the properties dialog box of this intelligent brick by selecting one of the new plates, right click and select "**Advance Joint Properties**" from the context menu.

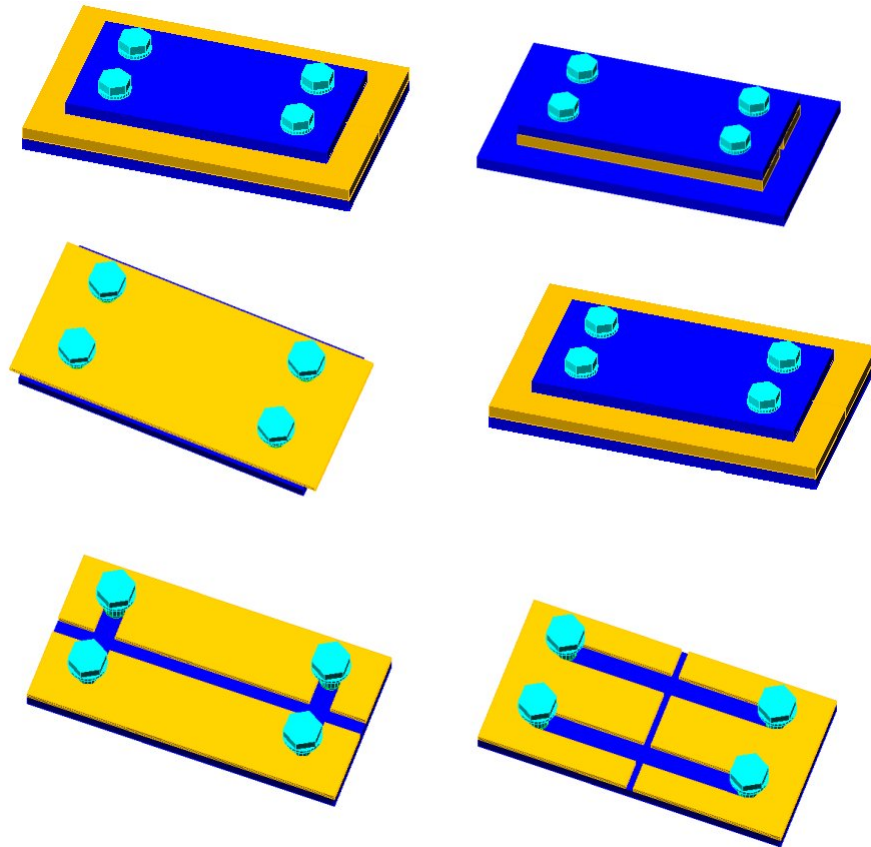

Shim plates at bolts

This intelligent brick adds up to two shims to an existing bolt pattern. The bolts can belong to a beam or to a plate. The orientation of the elements is irrelevant. They can also be part of an automatic joint or a structural element and can already have features and connecting elements. The brick adds the shim always to the whole bolt pattern with round holes. It is not possible to modify the hole properties.

The size of the shims depends on the size of the bolt pattern.

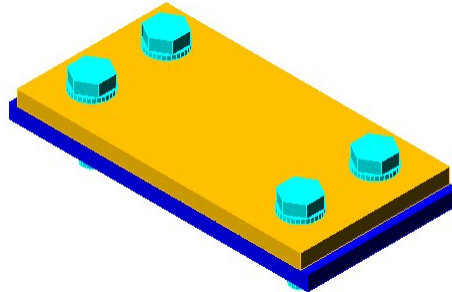

Example:

Click "**Shim plates at bolts**" from tool palette, category "**Custom Connection**".

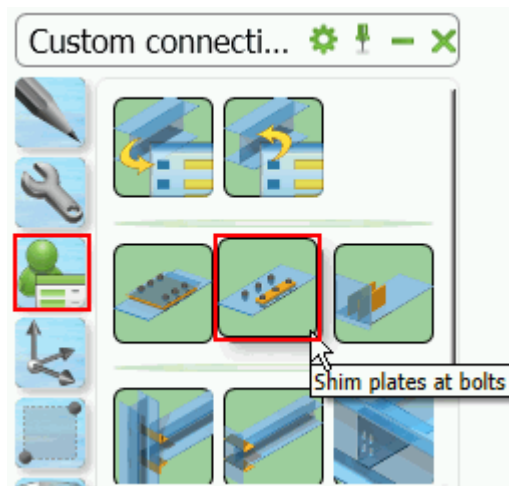

Select bolt /anchor

Select elements:

Select the bolt pattern by left click and confirm your selection by right click.

The command stopped and the shims are added.

The new plates are surrounded by a grey box, so that you can see in the model that the plates are not only common plates.

If you want to open this properties dialog box later again, please select one plate or the grey box, right click and choose from the context menu "**Advance Joint Properties**".

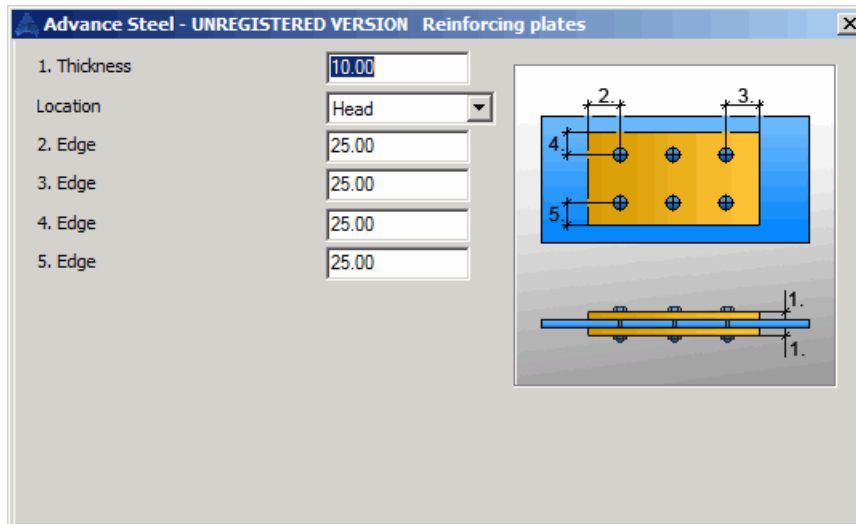

1. Thickness

Here you can specify the thickness of the shims.

Location

Here you can define the position of the shims. You can choose "Head", "Nut" or "Both".

With the last option two shims are added.

2. - 5. Edge

Here you can specify the four edge distances to the bolts. So the size of the shims depends on the size of the bolt pattern, which means it depends on the distance between the bolts.

You can open the properties dialog box of this intelligent brick by selecting one of the new plates, right click and select "Advance Joint Properties" from the context menu.

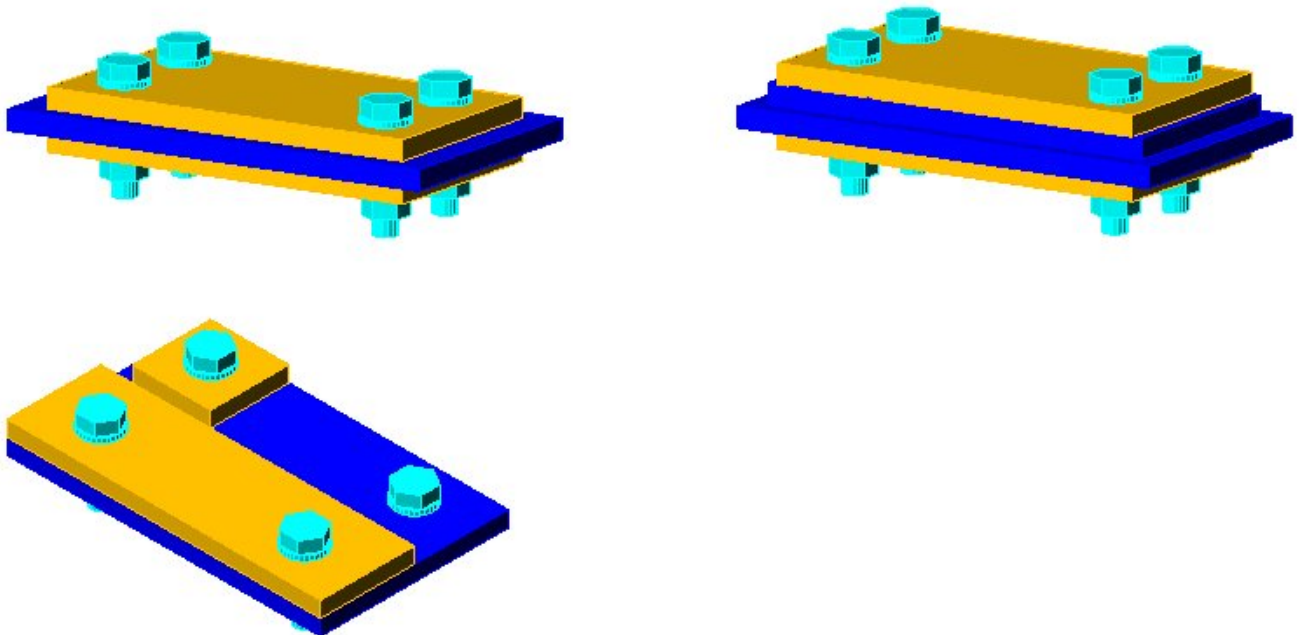

Outside stiffener

This intelligent brick adds up to three stiffeners to two existing elements (plate/plate, plate/beam or beam/beam). The orientation of the elements is irrelevant. They can also be part of an automatic joint or a structural element and can already have features and connecting elements.

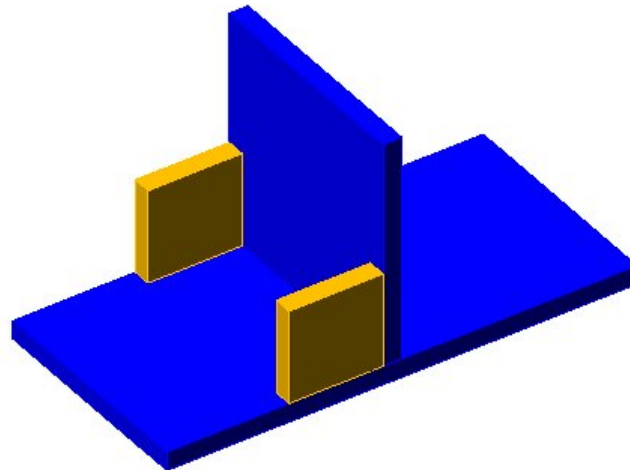

Example:

Click "**Outside stiffener**" from tool palette, category "**Custom Connection**".

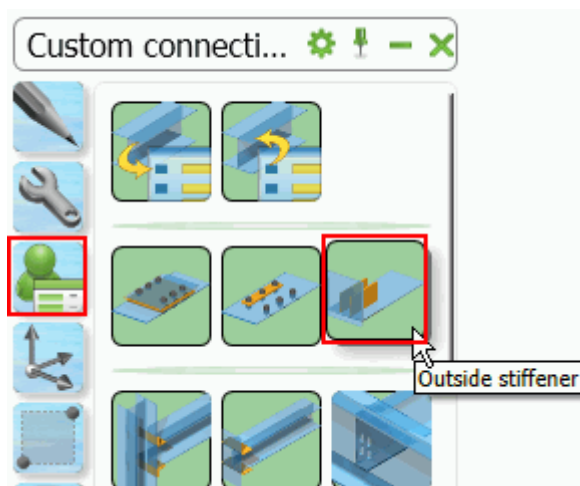

Select first object

Select elements:

Select the first element (beam or plate) by left click and confirm your selection by right click.

Select second object

Select elements:

Select the second element (beam or plate) by left click and confirm your selection by right click.

You should select the element you want to connect first, because the position of the stiffeners depends on this element. Then you must select the main beam / plate.

The command stopped automatically and the stiffeners are added.

The new plates are surrounded by a grey box, so that you can see in the model that the plates are not only common plates.

If you want to open this properties dialog box later again, please select one plate or the grey box, right click and choose from the context menu "**Advance Joint Properties**".

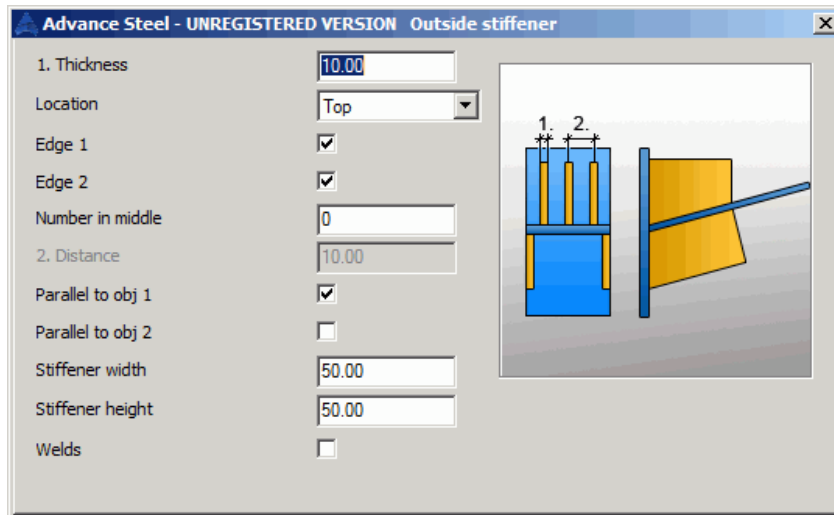
**1. Thickness**

Thickness of the stiffeners.

Location

Here you can specify the position of the stiffeners according to the main element.

Edge 1

If this box is activated, one stiffener will be added at one edge.

Edge 2

If this box is activated, one stiffener will be added at the other edge.

If no box is activated, one stiffener will be added in the center, because you have the value **1** by default in the field "**Number in middle**". If you activate both boxes later again, the centred stiffener will remain and you'll have to adapt it if needed.

Number in middle

Here you can define the number of centred stiffeners.

2. Distance

Here you can specify the distance between the centred stiffeners.

Parallel to obj 1

The edges of the new plate will be parallel to the edges of the first plate.

Parallel to obj 2

The edges of the new plate will be parallel to the edges of the second plate.

Stiffener width

Width of the stiffener

Stiffener height

Height of the stiffener

Welds

The plates will be weld together with a counter weld, thickness 0.1 mm.

You can modify the properties of the weld in its Autodesk Advance Steel **Properties**.

You can open the properties dialog box of this intelligent brick by selecting one of the new plates, right click and select "**Advance Joint Properties**" from the context menu.

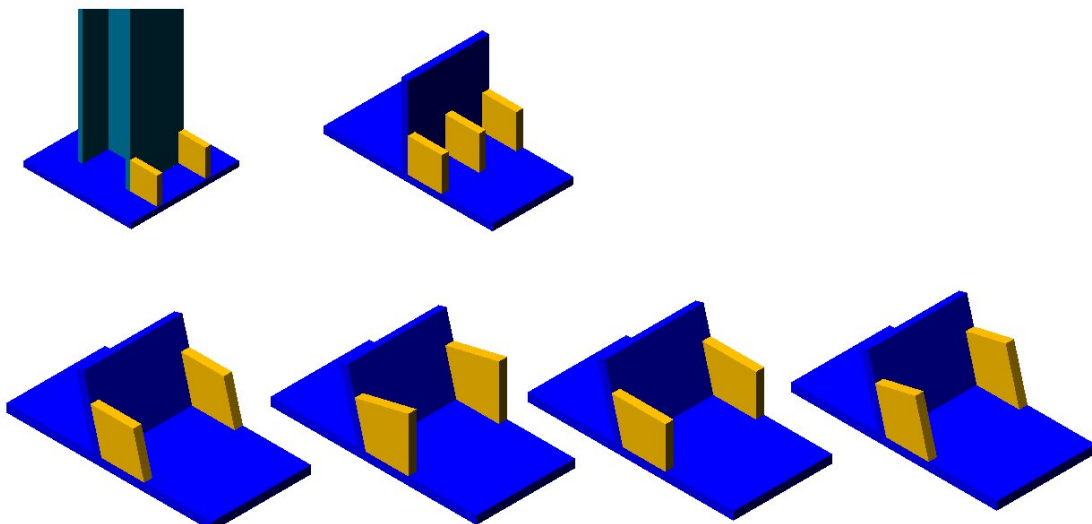

Beam on object reference to object

This intelligent brick depends on **two** reference elements (two beams) and adds up to two beams, e.g. angles for a joint. The orientation of the elements is irrelevant. They can also be part of an automatic joint or a structural element and can already have features and connecting elements.

The brick itself adds **no** features to the element you want to connect.

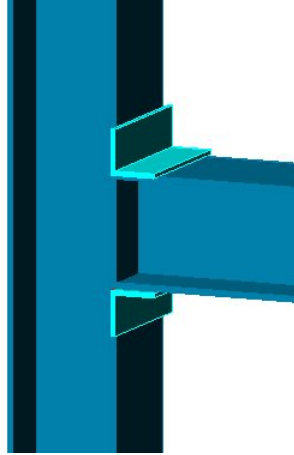

Example:

Click "**Beam on object reference to object**" from tool palette, category "**Custom Connection**".

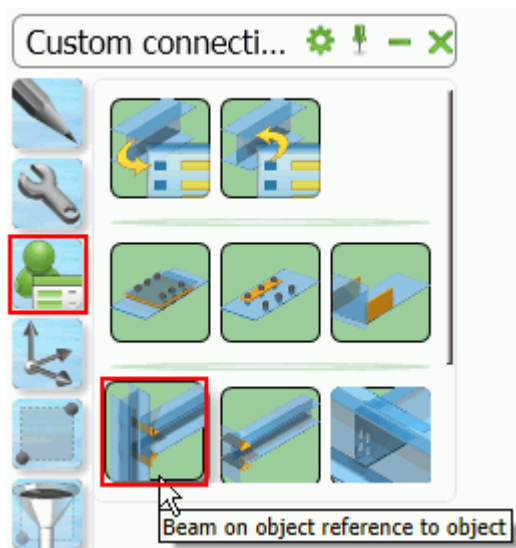

Select objects:

Select elements:

Select the main beam by left click and confirm your selection by right click.

Select objects:

Select elements:

Select the second beam by left click and confirm your selection by right click.

The command stopped and one angle is added.

The new angle is surrounded by a grey box, so that you can see in the model that it is not just a common beam.

If you want to open this properties dialog box later again, please select the angle or the grey box, right click and choose from the context menu "**Advance Joint Properties**".

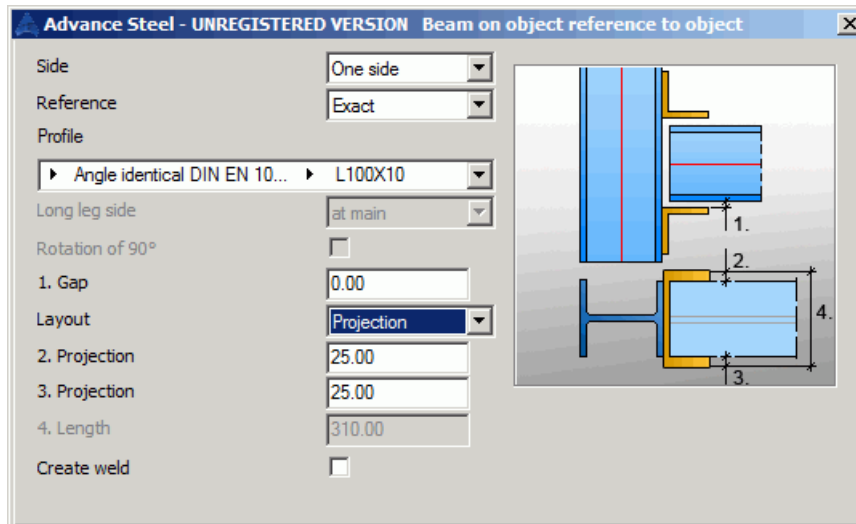

- Side** Here you can specify if you want to add one angle above or one angle below the second beam, or if you want to add two angles - one above and one below the second beam.
- Reference** Here you can specify, if you want to add the angle at the outer edged of the main beam or at the exact cross section (e.g. double t-profile: at the outer edges of the flanges – "**Casing**", or at the web – "**Exact**").
- Profile** Here you can define the type and size of the inserted beam(s). You have access to all profiles in database, user profile included.
- Long leg side** If you choose in option "**Profile**" an unequal angle, this box will be activated and you can define if the long leg should be at main or at second beam.
- Rotation of 90°** Here you can rotate the new profile by 90°. This works with all profile types except unequal angles, which can be rotated with the option "**Long leg side**" (see above).
- 1. Gap** Here you can define a gap to the second beam.
- Layout** Here you can specify how to define the size of the new profiles.
If you choose "**Projection**", then the fields "**2. Projection**" and "**3. Projection**" are activated and you can specify the length of the new profiles depending on the width of the second beam.
If you choose "**Total**", then the field "**4. Length**" is activated and you can enter the length of the new beams there.
- 2. Projection** Projection at one side of the second beam (see **Layout**).
- 3. Projection** Projection at the other side of the second beam (see **Layout**).
- 4. Length** Absolute length of the new beams (see **Layout**).
- Create weld** The new beams will be weld to the main beam with a fillet weld, thickness 4 mm. You can modify the properties of the weld in its Autodesk Advance Steel **Properties**.

You can open the properties dialog box of this intelligent brick by selecting one of the new beams, right click and select "**Advance Joint Properties**" from the context menu.

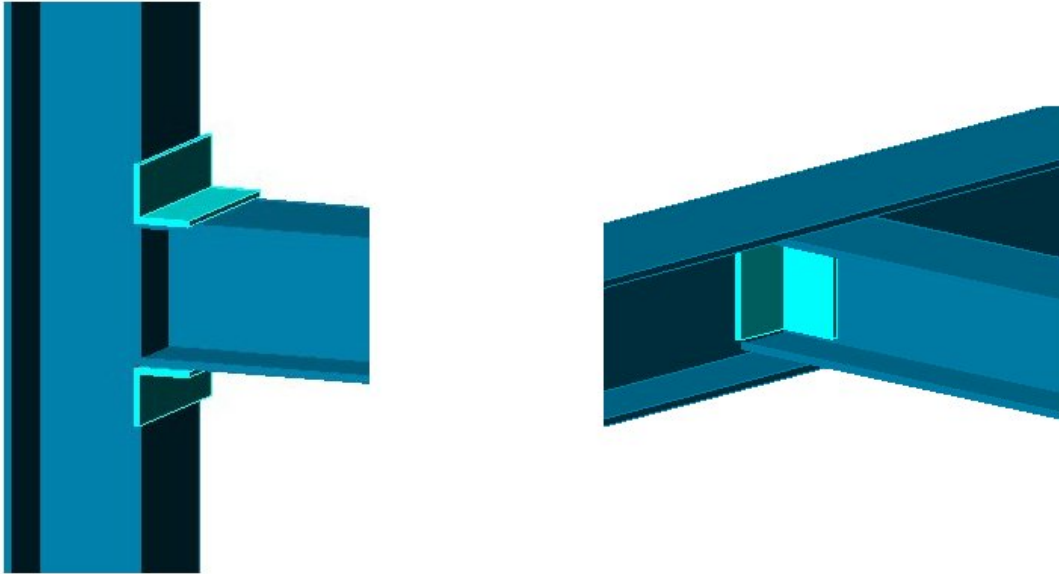

Plate on object reference to object

This intelligent brick depends on **two** reference elements (two beams) and adds up to two plates.

The orientation of the elements is irrelevant. They can also be part of an automatic joint or a structural element and can already have features and connecting elements.

The brick itself adds **no** features to the elements you want to connect. So e.g. the second beam must have all features.



Example:

Click "**Plate on object reference to object**" from tool palette, category "**Custom Connection**".

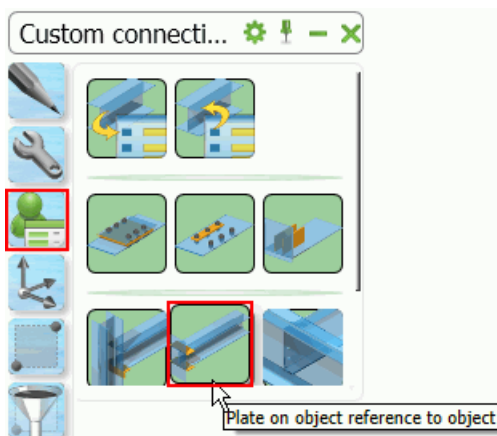

Select objects:

Select elements:

Select the main beam by left click and confirm your selection by right click.

Select objects:

Select elements:

Select the second beam by left click and confirm your selection by right click.

The command stopped and one plate is added.

The new plate is surrounded by a grey box, so that you can see in the model that it is not just a common plate.

If you want to open this properties dialog box later again, please select the plate or the grey box, right click and choose from the context menu "**Advance Joint Properties**".

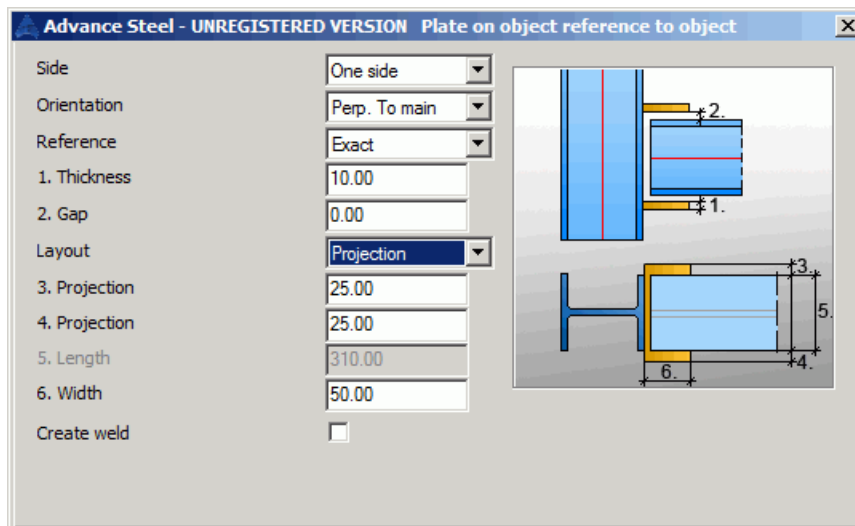

- Side** Here you can specify if you want to add one plate above or one plate below the second beam, or if you want to add two plates - one above and one below – the second beam.
- Orientation** If main and second beam are not perpendicular, you can specify here, if the plate should be "**Perp. To main**" or "**Parallel to sec.**"
- Reference** Here you can specify, if you want to add the plate at the outer edge of the main beam or at the exact cross section (e.g. double t-profile: at the outer edges of the flanges – "**Casing**", or at the web – "**Exact**").
- 1. Thickness** Thickness of the plate.
- 2. Gap** Here you can define a gap to the second beam.
- Layout** Here you can specify the way, how to define the size of the new plates. If you choose "**Projection**", then the fields "**3. Projection**" and "**4. Projection**" are activated and you can specify the length of the new plates depending on the width of the second beam. If you choose "**Total**", then the field "**5. Width**" is activated and you can enter the length of the new plates there.
- 3. Projection** Projection at one side of the second beam (see **Layout**).
- 4. Projection** Projection at the other side of the second beam (see **Layout**).
- 5. Length** Absolute length of the new plate (see **Layout**).
- 6. Width** Absolute width of the new plate (see **Layout**).
- Create weld** You can modify the properties of the weld in its Autodesk Advance Steel **Properties**.

You can open the properties dialog box of this intelligent brick by selecting one of the new plates, right click and select "**Advance Joint Properties**" from the context menu.



Hole in beam reference to beam

This intelligent brick depends on **two** reference elements (two beams) and adds one hole pattern to the main beam. The position of the holes can be defined depending to the main or the second beam. You can insert round or slotted holes.

The orientation of the elements is irrelevant. They can also be part of an automatic joint or a structural element and can already have features and connecting elements.

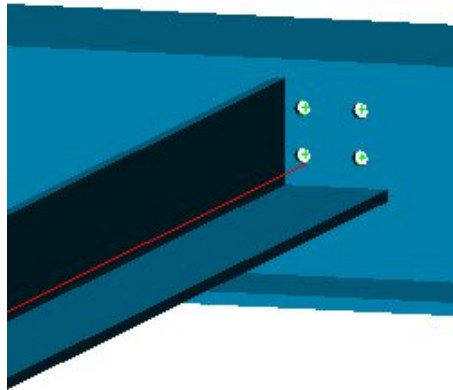

Example:

Click "**Hole in beam reference to beam**" from tool palette, category "**Custom Connection**".

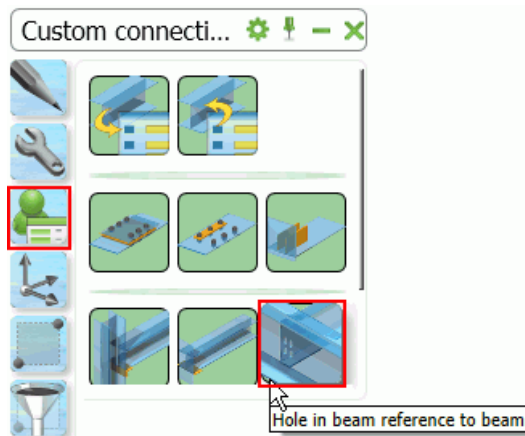

Select objects:

Select elements:

Select the main beam by left click and confirm your selection by right click.

Select objects:

Select elements:

Select the second beam by left click and confirm your selection by right click.

The command stops and one hole pattern is added to the main beam.

The holes are surrounded by a grey box so you can see in the model that they are not just a common hole pattern.

If you want to open this properties dialog box later again, please select one hole or the grey box, right click and choose from the context menu "**Advance Joint Properties**".

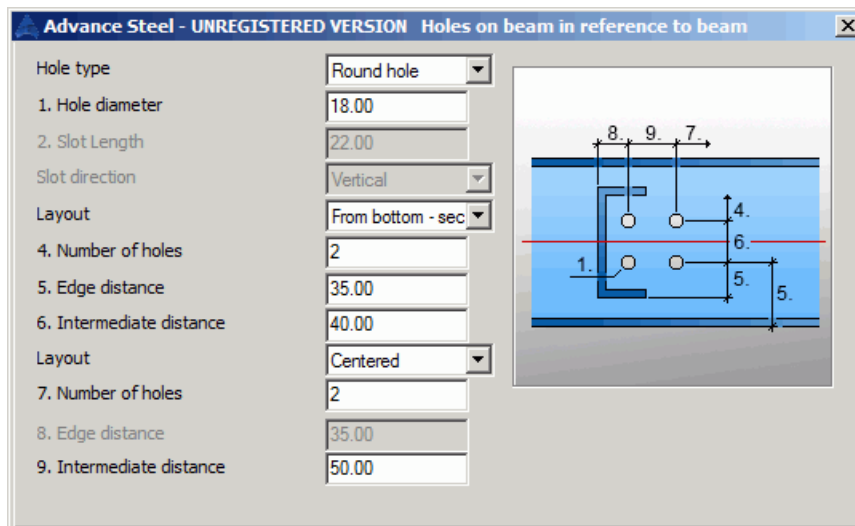
**Hole type**

Here you can switch between round and slotted hole.

1. Hole diameter

Here you can enter the hole's diameter.

2. Slot Length

This field will be activated if you select "**Slotted hole**" in field **Hole type**. Then you can enter the length of the slotted hole here

Slot direction

This field will be activated if you select "**Slotted hole**" in field **Hole type**. You can rotate the slotted holes by 90° here.

Layout

Here you can specify the holes position in direction of the main beam. You can choose "**Centered - main**", the holes are centred at main beam, "**From bottom - main**" the values you can enter refer to the lower edge of the main beam, "**Centered - sec**", the holes are centred at the second beam, "**From bottom - sec**", the values you can enter refer to the lower edge of the second beam.

4. Number of holes

Number of holes across the main beam.

5. Edge distance

This box will be activated if you choose "From bottom - main" or "From bottom - sec" in option **Layout**. Here you can specify the lower distance.

6. Intermediate distance

Here you can specify the distance between the holes across the main beam.

Layout

Here you can define how to set the position of the holes along the main beam.

7. Number of holes

Number of bolts along the main beam.

8. Edge distance

This box will be activated if you choose "**From back**" in option **Layout**. Here you can specify the distance to the back of the second beam.

9. Intermediate distance

Here you can specify the distance between the holes in along the main beam.

You can open the properties dialog box of this intelligent brick by selecting one of the new plates, right click and select "**Advance Joint Properties**" from the context menu.

Intelligent Bricks as Custom Connections

You are able to create Custom Connection very easily by using these intelligent bricks.

You can also use commands like **"Create by template"** from **"Extended Modeling"** ribbon, **"Joint Utilities"** area, because the behaviour of the intelligent bricks is the same as in automatic joints.

To define a Custom Connection you can combine the methods described above. That means you can put together a Custom Connection from single standard elements, automatic joints from Connection vault and intelligent bricks.

The example below was made from intelligent bricks and automatic joints (joint "Stiffener").

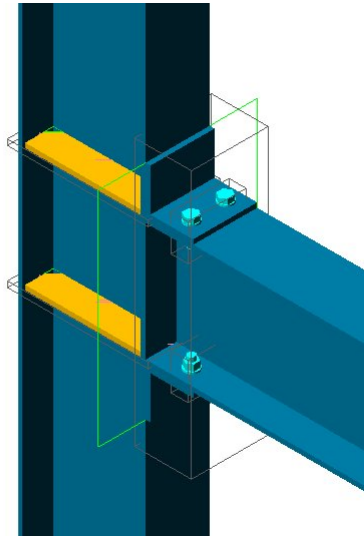

To create a Custom Connection from this joint now, you have to do the steps described above. Here it is important, too, to save the drawing in path

C:\ProgramData\Autodesk\Advance Steel\2015\Shared\ConnectionTemplates

and that all for the Custom Connections important elements (parts, connecting elements, features, grey boxes, etc.) are visible.

Advance Steel, Advance Concrete, Autodesk, AutoCAD, DWF and Revit are registered trademarks or trademarks of Autodesk, Inc. and/or its subsidiaries and/or affiliates in the USA and/or other countries. Gritec and Gritec Advance are registered trademarks of the Gritec group. All other brand names, product names or trademarks belong to their respective holders. Autodesk, Inc. and its subsidiaries Gritec SA and Gritec GmbH, reserve the right to alter product and services offerings, and specifications and pricing at any time without notice, and are not responsible for typographical or graphical errors that may appear in this document. © 2013 Autodesk, Inc., Gritec SA, and Gritec GmbH. All rights reserved.